



CONTRACTOR
CATALOGUE 2024/2025

Over 60 years of designing and manufacturing professional audio products in Italy, providing sound specialists worldwide with the best quality.

CRAFTED SOUND

Our Made in Italy DNA is driven by an inherent desire to explore and learn. **Research** and **innovation** are at the forefront of this pursuit, while the traditional methods of **craftsmanship continue to be respected**.

All departments are under one roof; a standout feature of our company that allows us to be self-reliant throughout every stage of the production process: R&D, woodworking, finishing, metalworking, electronic assembly, electronic testing, speakers assembly, acoustic testing and logistics, including audio system design, sales, marketing and after-sales services.



WE PROVIDE THE INDUSTRY PROFESSIONALS WITH 360° ASSISTANCE.

_Support

Planning the workflow, defining specifications and functionality, performing acoustical measurements according to national/international standards. Site inspection on demand.

_System Commissioning

Support during installation through remote or on-site inspections, audio system commissioning with acoustic measurements according to national/international standards, providing signed commissioning reports and on-site technical service.

Our long and dedicated experience in the audio industry makes us the reliable partners we are today.

_Acoustical Modelling

Producing 2D/3D models of the venue, performing electro-acoustic simulation using EASE software packages and others, providing technical and acoustical reports.

_Training

Technical training programmes for audio, acoustics and standards.

- 07** SPEAKERS
- 55** POWER AMPLIFIERS
- 65** CONTROL SYSTEMS
- 71** MUSIC SOURCES
- 75** CONFERENCE SYSTEMS
- 81** UHF MICROPHONE SYSTEMS
- 89** WIRED MICROPHONES
- 97** RACK SYSTEMS
- 103** AUDIO SOLUTIONS



SPEAKERS

- 8 POINT SOURCE
- 14 COLUMN & ARRAY
- 22 PENDANT
- 24 IN-CEILING
- 32 SPECIAL APPLICATION
- 40 SUBWOOFER
- 48 HORN & PROJECTOR
- 52 SURFACE-MOUNTING

KEIRON

Our extensive experience in the installation market has led to the creation of a new line of **passive coaxial point source** speakers, the KEIRON series. This combines powerful mechanics and acoustics with aesthetic appeal, providing professional performance while boasting an elegant and refined design.

Built in **wooden cabinets (HDF) with scratch-resistant paint finish**, the KEIRON series is equipped with the finest professional high-end components housed in clean and discreetly designed enclosures. Each of the four models has dedicated hardware to ensure **user-friendly handling** as well as **aesthetic elegance**. System connection is through 4-pole Euro-block in & thru connectors, ensuring a hassle-free installation process.

The KEIRON series offers an excellent solution for uniform sound distribution where intimate low volumes or high sound pressure are expected.

KEIRON can be easily integrated into any space. This series delivers unprecedented sound quality without compromising expectations, from small lounges to large halls requiring high dynamic range and intelligibility.

KEY FEATURES

- Uniform sound distribution
- Flexible installation features
- Custom finishes on request
- Euroblock in & thru connectors
- Elegant fabric-covered magnetic front frame
- Ideal match for KEIRON 8S subwoofer

The ARCHITECTURAL series



KEIRON 8C

Code (Black / White)		45384 / 46174
Configuration	way	2 coax
LF transducer	inch	8 - 2 vc
HF transducer	inch	1 - 1.4 vc
Recommended Amplifier	W	250
Rated Long Term Power (IEC)	W	125
Rated Short Term Power (IEC)	W	500
Rated impedance	Ω	8
Frequency response (@-6dB)	Hz	60 - 20.000
Sensitivity (@1W/1m)	dB	96
Max SPL (cont/peak)	dB	120 / 125
Nominal dispersion	H° x V°	80 conical
Materials		Wood / Fabric
Dimensions (WxHxD)	mm inch	260 x 400 x 226 10.23 x 16.14 x 8.89
Net weight	Kg Lb	7.6 16.8

KEIRON 5C

Code (Black / White)		45383 / 46173
Configuration	way	2 coax
LF transducer	inch	5 - 1.5 vc
HF transducer	inch	1 - 1 vc
Recommended Amplifier	W	120
Rated Long Term Power (IEC)	W	60
Rated Short Term Power (IEC)	W	240
Rated impedance	Ω	16
Frequency response (@-6dB)	Hz	80 - 20.000
Sensitivity (@1W/1m)	dB	93
Max SPL (cont/peak)	dB	114 / 117
Nominal dispersion	H° x V°	90 conical
Materials		Wood / Fabric
Dimensions (WxHxD)	mm inch	164 x 270 x 165 6.45 x 10.62 x 6.49
Net weight	Kg Lb	3.4 7.5



KEIRON 4C

- Compact cube-shaped 2-way coaxial system
- Ultimate clarity, detail and coverage in short-throw applications
- Smooth and consistent off-axis frequency response
- Extended application range when using subwoofer options
- Wide range of mounting options from ceilings to bookshelves

Code (Black / White)		45382 / 46172
Configuration	way	2 coax
LF transducer	inch	4 - 1.5 vc
HF transducer	inch	1 - 1 vc
Recommended Amplifier	W	100
Rated Long Term Power (IEC)	W	50
Rated Short Term Power (IEC)	W	200
Rated impedance	Ω	16
Frequency response (@-6dB)	Hz	100 - 20,000
Sensitivity (@1W/1m)	dB	91
Max SPL (cont/peak)	dB	111 / 114
Nominal dispersion	H° x V°	90 conical
Materials		Wood / Fabric
Dimensions	mm	132 x 132 x 132
	inch	5.19 x 2.19 x 5.19
Weight	Kg	2.6
	Lb	5.7

Related accessories



WM-68
Code (Black / White): 44856 / 44865
Wall metal bracket for Keiron 8C



WM-45
Code (Black / White): 44855 / 44864
Wall metal bracket for Keiron 4C/5C



A **TOUCH**
of **ELEGANCE**

PROJECT

Featuring an exclusive and compact design, the PROJECT series is the ideal solution for any type of installation that requires clear, clean sound suitable for **vocal and background music applications**.

PROJECT speakers incorporate an exclusive fully adjustable wall bracket for **easy, user-friendly installation**.

All models are made of ABS with a metal front grille. The PROJECT range is composed of six models equipped with a compact 2-way system from 3.5" to 6.5" and from 15W to 60W.

KEY FEATURES

- User-friendly and cost-effective installation
- 2-pin Euroblock input connector
- Bass-reflex enclosure design
- Low frequency extension with PROJECT 1020SA
- 70V/100V or 8Ω multitap line transformer
- Screwdriver-adjustable tap settings



PROJECT 600 SERIES

		660	640
Code (Black / White)		29229 / 32371	29227 / 32370
Configuration	Way	2	2
LF Transducer	inch	6.5	6.5
HF Transducer	inch	1	1
Recommended Amplifier	W	120	80
Rated Long Term Power (IEC)	W	60	40
Rated Short Term Power (IEC)	W	240	160
Rated Impedance	Ω	8	8
Transformer Taps	W	60 / 45 / 30 / 15	40 / 30 / 20 / 10
Frequency Response (@-10dB)	Hz	70 - 20.000	70 - 20.000
Sensitivity (@1W/1m)	dB	90	89
Max SPL (cont/peak)	dB	111 / 114	108 / 111
Nominal Dispersion	H° x V°	90 x 90	90 x 90
Materials		ABS / Metal	ABS / Metal
Dimensions (WxHxD)	mm	218 x 312 x 219	218 x 312 x 219
	inch	8.58 x 12.29 x 8.62	8.58 x 12.29 x 8.62
Net Weight	Kg	4.4	3.7
	Lb	9.70	8



PROJECT 500 SERIES

		550	530
Code (Black / White)		29225 / 32369	29223 / 32368
Configuration	Way	2	2
LF Transducer	inch	5	5
HF Transducer	inch	0.75	0.75
Recommended Amplifier	W	100	60
Rated Long Term Power (IEC)	W	50	30
Rated Short Term Power (IEC)	W	200	120
Rated Impedance	Ω	8	8
Transformer Taps	W	50 / 40 / 25 / 15	30 / 20 / 15 / 10
Frequency Response (@-10dB)	Hz	80 - 20.000	85 - 20.000
Sensitivity (@1W/1m)	dB	89	87.5
Max SPL (cont/peak)	dB	109 / 112	106 / 109
Nominal Dispersion	H° x V°	100 x 100	100 x 100
Materials		ABS / Metal	ABS / Metal
Dimensions (WxHxD)	mm	168 x 240 x 180	168 x 240 x 180
	inch	6.61 x 9.44 x 7.08	6.61 x 9.44 x 7.08
Net Weight	Kg	2.8	2.3
	Lb	6.17	5



PROJECT 300 SERIES

		320	315
Code (Black / White)		29221 / 32367	29350 / 32372
Configuration	Way	2	2
LF Transducer	inch	3.5	3.5
HF Transducer	inch	0.5	0.5
Recommended Amplifier	W	40	30
Rated Long Term Power (IEC)	W	20	15
Rated Short Term Power (IEC)	W	80	60
Rated Impedance	Ω	8	8
Transformer Taps	W	20 / 15 / 8 / 4	15 / 7.5 / 4 / 2
Frequency Response (@-10dB)	Hz	100 - 20.000	100 - 15.000
Sensitivity (@1W/1m)	dB	87	85
Max SPL (cont/peak)	dB	103 / 106	100 / 103
Nominal Dispersion	H° x V°	120 x 120	120 x 120
Materials		ABS / Metal	ABS / Metal
Dimensions (WxHxD)	mm	143 x 204 x 162	143 x 204 x 162
	inch	5.62 x 8.03 x 6.37	5.62 x 8.03 x 6.37
Net Weight	Kg	1.6	1.4
	Lb	3.52	3.08

VERTUS DLA

Constructed in aluminium cabinets, the VERTUS DLA series is a **digitally steerable** self-powered line array.

Available in two different models – the **DLA 1244A** composed of 12 x 4" woofers and 4 x 1" **neodymium** dome tweeter, and the **DLA 804A** composed of 8 x 4" full range woofers – these speakers are the perfect solution to many problems related to **reverberant environments**.

VERTUS DLA are modular elements that can be combined to form highly directional long column arrays. The digital steering technology enable the directivity control.

With an extended frequency response, these models are recommended for both vocal and music reproduction. It is also possible to extend lower-frequency performance further by connecting a self-powered sub to the dedicated Euroblock connector.

The wide range of controls makes DLA speakers **very easy to configure**, either with the onboard control panel or by dedicated PC software with FBT USB-RS485 converter.

KEY FEATURES

- Improves speech intelligibility in challenging acoustic environments
- Digital steerable vertical beam angle and coverage
- Easy to set up even without a PC
- High directivity to reverberant ratio
- Powerful onboard multichannel amplifier



VERTUS DLA 1244A

Code		36187
Configuration	Way	16 active
LF Transducer	inch	12 x 4 - 1 vc
HF Transducer	inch	4 x 1 - 1 vc
Built-in Amplifier (cont)	W	16 x 40
Built-in Amplifier (max)	W	16 x 50
Built-in Amplifier (peak)	W	16 x 100
Input Impedance	Ω	22.000
Transformer Taps	W	---
Frequency Response (@-6dB)	Hz	100 - 20.000
Sensitivity (@1W/1m)	dB	---
Max SPL (cont/peak)	dB	123 / 126
Nominal Dispersion	H° x V°	100 x digitally controlled
Materials		Aluminium
Dimensions (WxHxD)	mm	130 x 1695 x 131
	inch	5.11 x 66.73 x 5.15
Net Weight	Kg	22
	Lb	48.5



VERTUS DLA 804A

Code		36186
Configuration	Way	8 active
LF Transducer	inch	8 x 4 neo - 1 vc
HF Transducer	inch	---
Built-in Amplifier (cont)	W	8 x 40
Built-in Amplifier (max)	W	8 x 50
Built-in Amplifier (peak)	W	8 x 100
Input Impedance	Ω	22.000
Transformer Taps	W	---
Frequency Response (@-6dB)	Hz	120 - 20.000
Sensitivity (@1W/1m)	dB	---
Max SPL (cont/peak)	dB	120 / 123
Nominal Dispersion	H° x V°	100 x digitally controlled
Materials		Aluminium
Dimensions (WxHxD)	mm	130 x 964 x 131
	inch	5.11 x 37.95 x 5.15
Net Weight	Kg	13
	Lb	26.66

Related accessories



VT-J DLA
Code: 38381
Safety flange for VERTUS DLA



VT-W604
Code (Black / White): 35722 / 37043
Directional wall mount for CLA 604

VERTUS CLA

The VERTUS CLA series incorporates professional line array technology in extremely compact and elegant speaker columns.

The 4" VERTUS CLA 604 and CLA 204T models share the same extruded aluminium cabinet, woofers and tweeters. The **CLA 604** is a true professional line array system equipped with six 4" custom woofers with 1" voice coil combined with four 1" **neodymium** dome tweeter on waveguide. It is dedicated to those demanding applications where acoustic intelligibility is required in particularly challenging environments. The **CLA 204T** point source delivers the same quality in a smaller cabinet with minimalist design, which makes it suitable for integration in architectural designs.

Suitable for both indoor and **IP55-rated** outdoor applications, the 3" VERTUS CLA product range offers powerful new features to address extreme conditions. The **CLA 803T**, **CLA 403T** line array and compact 2-way **CLA 203T** point source models share the same sleek, lightweight and durable powder-coated aluminium housing. Completely **dustproof** and **weatherproof** thanks to the **hydrophobic fabric** mounted on the front grille. This range of speakers provides **great flexibility** in challenging venues thanks to the integrated passive directivity control system. Mechanical accessories allow them to be installed in different configurations, individually (on wall) or stacked (in a flown array).



VERTUS CLA 604

- Narrow sound dispersion along vertical axis
- Suitable for mid-throw applications
- 2-way high performance column speaker design
- Also available in black
- EN 54-24

Code		36145
Configuration	Way	2
LF Transducer	inch	6 x 4 - 1 vc
HF Transducer	inch	4 x 1 - 1 vc
Recommended Amplifier	W	250
Rated Long Term Power (IEC)	W	100
Rated Short Term Power (IEC)	W	500
Rated Impedance	Ω	8
Transformer Taps	W	100 / 50 / Bypass
Frequency Response (@-6dB)	Hz	140 - 20.000
Sensitivity (@1W/1m)	dB	91
Max SPL (cont/peak)	dB	110 / 118
Nominal Dispersion	H° x V°	100 x 15
Materials		Aluminium
Dimensions (WxHxD)	mm inch	130 x 849 x 133 5.11 x 33.42 x 5.33
Net Weight	Kg Lb	10.5 23.14

Related accessories

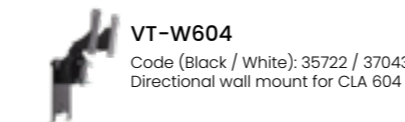

VT-W604
Code (Black / White): 35722 / 37043
Directional wall mount for CLA 604



VM-23
Code: (Black / White): 45782 / 45783
Directional wall mount for CLA 203T / 204T



VT-J 604
Code: 41777
Safety flange for VERTUS CLA



VERTUS CLA 204T

- High level of sound definition
- Compact and paintable aluminium cabinet
- Provides a great audio experience combined with KEIRON 8S
- EN 54-24

Code (Black / White)		45502 / 45501
Configuration	Way	2
LF Transducer	inch	4 - 1 vc
HF Transducer	inch	1 - 1 vc
Recommended Amplifier	W	80
Rated Long Term Power (IEC)	W	40
Rated Short Term Power (IEC)	W	160
Rated Impedance	Ω	8
Transformer Taps	W	30 / 20 / 10 / 5 / Bypass
Frequency Response (@-6dB)	Hz	130 - 20.000
Sensitivity (@1W/1m)	dB	88
Max SPL (cont/peak)	dB	103 / 110
Nominal Dispersion	H° x V°	120 x 130
Materials		Aluminium
Dimensions (WxHxD)	mm inch	130 x 312 x 130 5.11 x 12.28 x 5.11
Net Weight	Kg Lb	3.5 7.71



VERTUS CLA 803T

- Low profile enclosure and custom colours blend into any environment
- Conveys sound proximity to audience
- Flexible arrayable configuration with CLA 803T and CLA 403T
- Ideal match for CLA 112S subwoofer for background or foreground music applications
- EN 54-24 / IP55

Code (Black / White)		41806 / 41823
Configuration	Way	1
Fullrange Transducer	inch	8 x 3 - 0.75 vc
Recommended Amplifier	W	200
Rated Long Term Power (IEC)	W	100
Rated Short Term Power (IEC)	W	400
Rated Impedance	Ω	8
Transformer Taps	W	50 / 100
Frequency Response (@-6dB)	Hz	150 - 20.000
Sensitivity (@1W/1m)	dB	94
Max SPL (cont/peak)	dB	112 / 121
Nominal Dispersion	H° x V°	125 x 18 narrow mode 125 x 26 wide mode
Materials		Aluminium
Dimensions (WxHxD)	mm inch	100 x 704 x 125 3.93 x 27.71 x 4.92
Net Weight	Kg Lb	5.5 12.1

Related accessories



VT-F3

Code: (Black / White): 41795 / 41820
Flying bar for CLA 803T / 403T



VT-W3

Code: (Black / White): 41797 / 41821
Wall mount for CLA 803 / 403

A true **PROFESSIONAL** **LINE ARRAY** system

The **perfect application** for challenging environments where **good sound quality** is required.

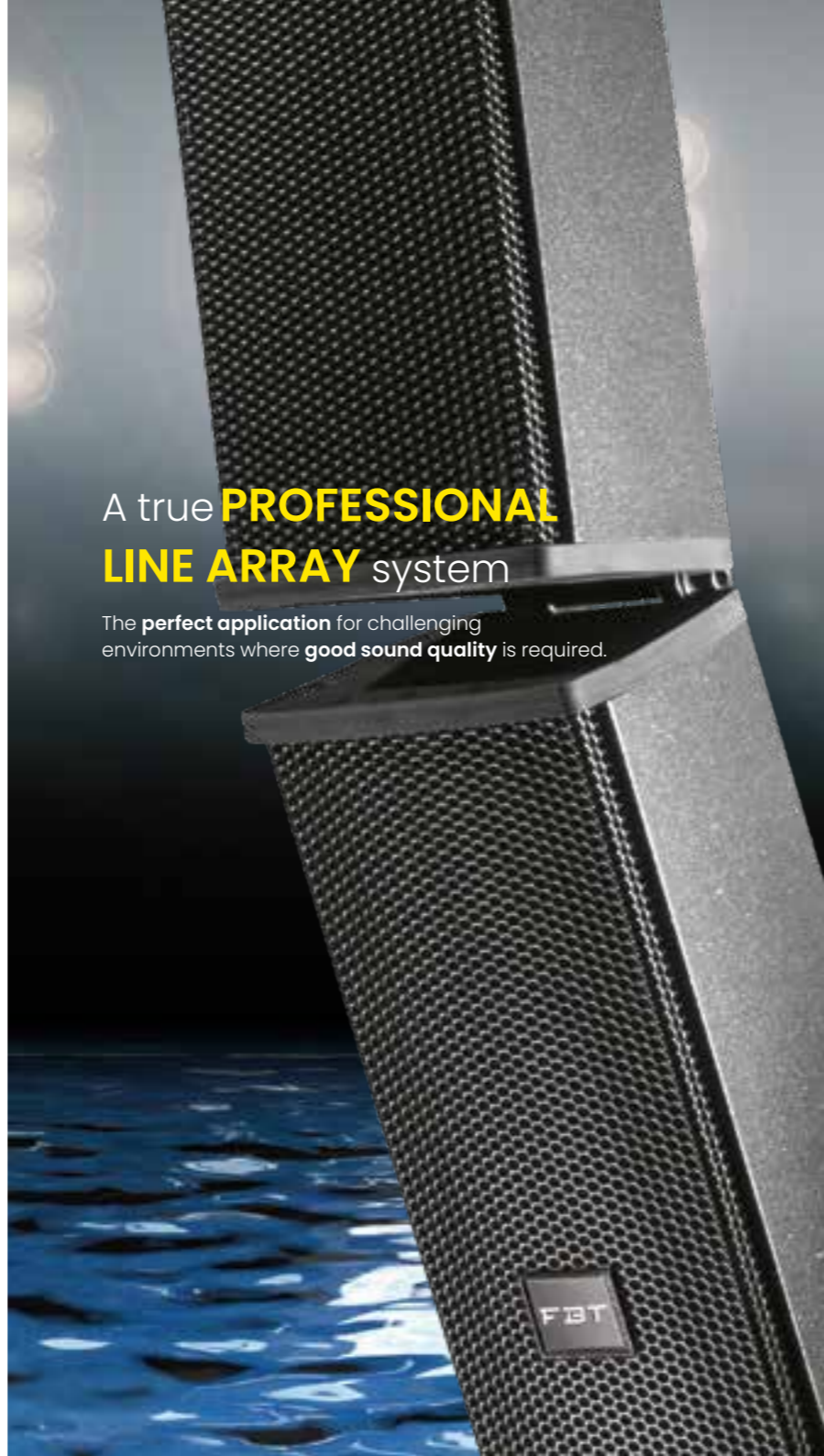

VERTUS CLA 403T

- Low profile enclosure and custom colours blend into any environment
- Conveys sound proximity to audience
- Flexible arrayable configuration with CLA 803T and CLA 403T
- Ideal match for CLA 112S subwoofer for background or foreground music applications
- EN 54-24 / IP55

Code (Black / White)		41807 / 41824
Configuration	Way	1
Fullrange Transducer	inch	4 x 3 - 0.75 vc
Recommended Amplifier	W	120
Rated Long Term Power (IEC)	W	60
Rated Short Term Power (IEC)	W	240
Rated Impedance	Ω	16
Transformer Taps	W	25 / 50
Frequency Response (@-6dB)	Hz	150 - 20.000
Sensitivity (@1W/1m)	dB	91
Max SPL (cont/peak)	dB	106 / 115
Nominal Dispersion	H° x V°	125 x 28 narrow mode 125 x 36 wide mode
Materials		Aluminium
Dimensions (WxHxD)	mm inch	100 x 368 x 125 3.93 x 14.48 x 4.92
Net Weight	Kg Lb	3 6.6



Related accessories



VT-J3

Code: (Black / White): 41794 / 41819
Joint bar 0° -15° for CLA 803 / 403



VT-WH3

Code: (Black / White): 41798 / 41822
Wall mount for CLA 803 / 403



VT-JF3

Code: 41799
Joint bar for CLA 803 / 403



VM-23

Code: (Black / White): 45782 / 45783
Directional wall mount for CLA 203 / 204

VERTUS CLA 203T

- 2-way ultra-compact version of CLA range
- Bright sound reproduction
- Very compact, extruded aluminium housing
- Ideal match for KEIRON 8S or CLA 112S subwoofers for background or foreground music applications
- EN 54-24 / IP55

Code (Black / White)		45510 / 45351
Configuration	Way	2
LF Transducer	inch	2 x 3 - 0.75 vc
HF Transducer	inch	1 - 1 vc
Recommended Amplifier	W	60
Rated Long Term Power (IEC)	W	30
Rated Short Term Power (IEC)	W	120
Rated Impedance	Ω	8
Transformer Taps	W	5 / 10 / 20 / 30
Frequency Response (@-6dB)	Hz	160 - 20.000
Sensitivity (@1W/1m)	dB	87
Max SPL (cont/peak)	dB	101 / 108
Nominal Dispersion	H° x V°	120 x 110
Materials		Aluminium
Dimensions (WxHxD)	mm inch	100 x 249 x 105 3.93 x 9.80 x 4.13
Net Weight	Kg Lb	1.5 3.3



CS SERIES

CS Series is designed to offer a cost-effective solution without compromising on quality. Housed in a robust aluminium cabinet, this column line array series features enhanced durability and a minimal visual impact.

"L-bracket" mounting system facilitates fast and easy installation, saving time and effort.

KEY FEATURES

- Easy installation
- Robust extruded aluminium housing
- Minimal visual impact
- High efficiency for vocal applications



SLIM columns
that fit **EVERYWHERE**



CS 3180T

Code		37924
Configuration	Way	2
LF Transducer	inch	14 x 2 - 1 vc
HF Transducer	inch	1 - 1 vc
Recommended Amplifier	W	160
Rated Long Term Power (IEC)	W	80
Rated Short Term Power (IEC)	W	320
Rated Impedance	Ω	28
Transformer Taps	W	80 / 40 / 20 / Bypass
Frequency Response (@-10dB)	Hz	200 - 15.000
Sensitivity (@1W/1m)	dB	91
Max SPL (cont/peak)	dB	113 / 116
Nominal Dispersion	H° x V°	150 x 20
Materials		Aluminium
Dimensions (WxHxD)	mm inch	74.5 x 1018 x 69 2.93 x 40.07 x 2.7
Net Weight	Kg Lb	4.6 10.14



CS 3150T

Code		37923
Configuration	Way	2
LF Transducer	inch	10 x 2 - 1 vc
HF Transducer	inch	1 - 1 vc
Recommended Amplifier	W	100
Rated Long Term Power (IEC)	W	50
Rated Short Term Power (IEC)	W	200
Rated Impedance	Ω	20
Transformer Taps	W	50 / 25 / 12.5 / Bypass
Frequency Response (@-10dB)	Hz	200 - 15.000
Sensitivity (@1W/1m)	dB	91
Max SPL (cont/peak)	dB	111 / 114
Nominal Dispersion	H° x V°	150 x 30
Materials		Aluminium
Dimensions (WxHxD)	mm inch	74.5 x 802 x 69 2.93 x 31.57 x 2.7
Net Weight	Kg Lb	3.8 8.37



CS 3130T

Code		37922
Configuration	Way	2
LF Transducer	inch	4 x 2 - 1 vc
HF Transducer	inch	1 - 1 vc
Recommended Amplifier	W	60
Rated Long Term Power (IEC)	W	30
Rated Short Term Power (IEC)	W	120
Rated Impedance	Ω	8
Transformer Taps	W	30 / 15 / 7.5 / Bypass
Frequency Response (@-10dB)	Hz	180 - 18.000
Sensitivity (@1W/1m)	dB	91
Max SPL (cont/peak)	dB	109 / 112
Nominal Dispersion	H° x V°	150 x 40
Materials		Aluminium
Dimensions (WxHxD)	mm inch	74.5 x 405 x 69 2.93 x 15.94 x 2.7
Net Weight	Kg Lb	1.8 3.96

LIBRA 5CT

The new **LIBRA 5CT** pendant speaker has been engineered specifically for high- or open-ceiling spaces such as airports, malls, retail units, restaurants and more. Its elegant design houses a 5" 2-way **coaxial transducer** in a ported **high-quality polypropylene enclosure**.

LIBRA 5CT produces a natural sound which is perfect for both speech and music applications. The rear cover can be fitted after installation, hiding the connection and suspension elements of the speaker.



When **FORM** meets **FUNCTIONALITY**



LIBRA 5CT

- Natural audio reproduction
- Compact, lightweight enclosure
- 2-way loudspeaker design
- 70V/100V or 16Ω multitap line transformer
- Bass reflex enclosure
- Ideal match for LIBRA 8S subwoofer
- EN 54-24

Code (Black / White)		45511 / 45483
Configuration	Way	2 coax
LF Transducer	inch	5
HF Transducer	inch	1
Recommended Amplifier	W	120
Rated Long Term Power (IEC)	W	60
Rated Short Term Power (IEC)	W	240
Rated Impedance	Ω	16
Transformer Taps	W	64 / 32 / 16 / 10 / Bypass
Frequency Response (@-6dB)	Hz	80 - 20.000
Sensitivity (@1W/1m)	dB	86
Max SPL (cont/peak)	dB	104 / 110
Nominal Dispersion	H° x V°	85 conical
Materials		ABS / Metal
Dimensions (WxHxD)	mm inch	Ø215 x 275 Ø8.46 x 10.82
Net Weight	Kg Lb	4 8.81

ELYSION

Specifically designed for applications that demand top-notch music reproduction, clear speech intelligibility and a sleek design that seamlessly blends into any environment. ELYSION 4CT is a 4" 2-way speaker with a shallow cabinet for **easy installation, suitable for most false ceilings**. ELYSION 6CT is a 6.5" 2-way speaker that guarantees increased power output.

Regardless of differing material and dimensions, the models share the same cabinet design concept: a **magnetic paintable front grille**, springlock mounting clamp and safety hook and front power switch. Both models are equipped with **line transformers for Hi-Z applications** and a **5-pin ceramic terminal block** with thermal fuse for connecting further speakers directly.

All models are available with black or white front grille as standard, and **can be customised** to suit any décor.

Whether you are looking to upgrade your home audio system, enhance your office's sound quality or create an immersive entertainment space, ELYSION's in-ceiling speakers are the perfect solution. Experience **high-quality sound** with **deep bass** like never before, without compromising on style or integration.

KEY FEATURES

- Clear and warm low-frequency reproduction
- Bass reflex enclosure
- Fast installation with springlock mounting clamps
- Paintable magnetic front grille
- Ideal match for ELYSION 8S subwoofer
- EN 54-24



ELYSION 6CT

Code (Black / White)		47328 / 47329
Configuration	Way	2
LF Transducer	inch	6.5
HF Transducer	inch	0.75
Recommended Amplifier	W	120
Rated Long Term Power (IEC)	W	60
Rated Short Term Power (IEC)	W	240
Rated Impedance	Ω	16
Transformer Taps (@100V)	W	60 / 30 / 15 / 7.5 / Bypass
Frequency Response (@-6dB)	Hz	62 - 20.000
Sensitivity (@1W/1m)	dB	87
Max SPL (cont/peak)	dB	111 / 114
Nominal Dispersion	H° x V°	100 conical
Materials		ABS / Steel
Dimensions (WxHxD)	mm inch	Ø323 x 202 Ø12.7 x 7.9
Net Weight	Kg Lb	6.5 14.3



ELYSION 4CT

Code (Black / White)		47330 / 47331
Configuration	Way	2
LF Transducer	inch	4
HF Transducer	inch	0.75
Recommended Amplifier	W	60
Rated Long Term Power (IEC)	W	30
Rated Short Term Power (IEC)	W	120
Rated Impedance	Ω	16
Transformer Taps (@100V)	W	30 / 15 / 7.5 / Bypass
Frequency Response (@-6dB)	Hz	70 - 20.000
Sensitivity (@1W/1m)	dB	87
Max SPL (cont/peak)	dB	104 / 107
Nominal Dispersion	H° x V°	120 conical
Materials		ABS / Steel
Dimensions (WxHxD)	mm inch	Ø323 x 98 Ø12.7 x 3.8
Net Weight	Kg Lb	3 6.6

CSL SERIES

CSL series provides reliable and cost effective in-ceiling solutions for background music and accurate speech reproduction.

Different models meet different requirements in terms of mechanical size, backcan provision, full-range 2-way electro-acoustic configuration, **waterproof protection degree** and materials (metal and/or sturdy ABS).

KEY FEATURES

- 2-way loudspeaker configuration
- Clear voice reproduction
- Metal backcan
- Dog ear mounting system
- 70V/100V or 8Ω multitap line transformer
- Spring clip input connector



CSL 840TIC

Code		29418
Configuration	Way	2
LF Transducer	inch	8
HF Transducer	inch	0.5
Recommended Amplifier	W	80
Rated Long Term Power (IEC)	W	40
Rated Short Term Power (IEC)	W	160
Rated Impedance	Ω	8
Transformer Taps	W	40 / 20 / 10 / 5 / Bypass
Frequency Response (@-6dB)	Hz	90 - 20.000
Sensitivity (@1W/1m)	dB	88
Max SPL (cont/peak)	dB	107 / 110
Nominal Dispersion	H° x V°	90 conical
Materials		ABS / Metal
Dimension (WxHxD)	mm inch	Ø270 x 185 Ø10.62 x 7.28
Net Weight	Kg Lb	3.1 6.83



CSL 630TIC

Code		29417
Configuration	Way	2
LF Transducer	inch	6
HF Transducer	inch	0.5
Recommended Amplifier	W	60
Rated Long Term Power (IEC)	W	30
Rated Short Term Power (IEC)	W	120
Rated Impedance	Ω	8
Transformer Taps	W	30 / 15 / 7.5 / 3.8
Frequency Response (@-6dB)	Hz	120 - 20.000
Sensitivity (@1W/1m)	dB	88
Max SPL (cont/peak)	dB	106 / 109
Nominal Dispersion	H° x V°	90 conical
Materials		ABS / Metal
Dimensions (WxHxD)	mm inch	Ø230 x 150 Ø9.05 x 5.90
Net Weight	Kg Lb	2.3 5.07



CSL 520TIC

Code		29416
Configuration	Way	2
LF Transducer	inch	5
HF Transducer	inch	0.5
Recommended Amplifier	W	40
Rated Long Term Power (IEC)	W	20
Rated Short Term Power (IEC)	W	80
Rated Impedance	Ω	8
Transformer Taps	W	20 / 10 / 5 / 2.5 / Bypass
Frequency Response (@-6dB)	Hz	120 - 20.000
Sensitivity (@1W/1m)	dB	88
Max SPL (cont/peak)	dB	104 / 107
Nominal Dispersion	H° x V°	90 conical
Materials		ABS / Metal
Dimensions (WxHxD)	mm inch	Ø203 x 145 Ø7.99 x 5.70
Net Weight	Kg Lb	1.7 3.74



CSL 106T

- Ultra-deep enclosure design
- Cost-effective solution for public spaces
- Lightweight cabinet
- Springlock mounting clamps

Code		29427
Configuration	Way	1
Fullrange Transducer	inch	5
Recommended Amplifier	W	---
Rated Long Term Power (IEC)	W	---
Rated Short Term Power (IEC)	W	---
Rated Impedance	Ω	---
Transformer Taps	W @100V	6 / 3
Frequency Response (@-6dB)	Hz	100 - 15,000
Sensitivity (@1W/1m)	dB	93
Max SPL (cont/peak)	dB	101 / 104
Nominal Dispersion	H° x V°	90 conical
Materials		ABS / Metal
Dimensions (WxHxD)	mm inch	Ø175 x 60 Ø2.36 x 6.88
Net Weight	Kg Lb	0.5 1.10



CSL 606TWP

- 2-way loudspeaker configuration
- Harmonious music reproduction
- Suitable for damp environments
- Screw fixing system

Cod		29428
Configuration	Way	2
LF Transducer	inch	5
HF Transducer	inch	1
Recommended Amplifier	W	---
Rated Long Term Power (IEC)	W	---
Rated Short Term Power (IEC)	W	---
Rated Impedance	Ω	---
Transformer Taps	W	20
Frequency Response (@-6dB)	Hz	95 - 20,000
Sensitivity (@1W/1m)	dB	90
Max SPL (cont/peak)	dB	103 / 106
Nominal Dispersion	H° x V°	90 conical
Materials		ABS
Dimensions (WxHxD)	mm inch	Ø167 x 115 Ø6.57 x 4.52
Net Weight	Kg Lb	0.7 1.54

MCSL SERIES

The in-ceiling MCSL series comprises two models that house 2.5" and 4" full-range loudspeakers. These general purpose speakers are suitable for **background music** and **paging applications**. The **TWP** model is particularly suitable for bathrooms and other **high humidity areas**.

The MCSL series is characterised by an ultra-compact design combined with a fine perforated grille, making the speaker aesthetically pleasing. In addition, the MCSL range is designed to be user-friendly, with an **easy installation process** that uses a spring mechanism.



MCSL 006TWP

- Ultra-compact design
- Waterproof enclosure
- Powder coated iron front grille
- Springlock mounting clamps

Code		29426
Configuration	Way	1
Fullrange Transducer	inch	4
Recommended Amplifier	W	---
Rated Long Term Power (IEC)	W	---
Rated Short Term Power (IEC)	W	---
Rated Impedance	Ω	---
Transformer Taps	W	6 / 3
Frequency Response (@-6dB)	Hz	160 - 20.000
Sensitivity (@1W/1m)	dB	91
Max SPL (cont/peak)	dB	99 / 102
Nominal Dispersion	H° x V°	100 conical
Materials		ABS / Metal
Dimensions (WxHxD)	mm inch	Ø140 x 122 Ø5.51 x 4.80
Net Weight	Kg Lb	0.88 1.94



MCSL 006TW

- Ultra-slim design
- Sleek and modern look
- Lightweight cabinet
- Springlock mounting clamps

Code		29425
Configuration	Way	1
Fullrange Transducer	inch	2.5
Recommended Amplifier	W	---
Rated Long Term Power (IEC)	W	---
Rated Short Term Power (IEC)	W	---
Rated Impedance	Ω	---
Transformer Taps	W	6 / 3
Frequency Response (@-6dB)	Hz	120 - 15.000
Sensitivity (@1W/1m)	dB	87
Max SPL (cont/peak)	dB	95 / 98
Nominal Dispersion	H° x V°	120 conical
Materials		ABS / Metal
Dimensions (WxHxD)	mm inch	Ø103 x 80 Ø4.05 x 3.14
Net Weight	Kg Lb	0.5 1.10

SHADOW

A complete range of **high-performance speakers** designed to provide superior music and vocal reproduction in **rough or severe weather conditions**, ensuring **long-term exposure**.

The SHADOW series is composed of three different models, 5", 8" and 12", manufactured from top quality materials such as a **rotomolded enclosure** and fully UV protected and stainless steel hardware.

Additionally, the **IP55 certification** makes SHADOW the right choice for a wide range of applications, from sport fields to swimming pools and skiing areas to tropical beach resorts.

KEY FEATURES

- Sturdy rotomolded enclosure
- Water-resistant grille with three layers of protection
- Stainless steel hardware
- IP55-rated

IP55

The **all-weather SHADOW speaker range** ensures long-term reliability for temporary and permanent outdoor installations. These systems are manufactured to meet the most extreme standards enforced by International Protection Rating IP55.

Finished in a standard grey colour (RAL 7011).



SHADOW 112CT

Code		36194
Configuration	Way	2 coax
LF Transducer	inch	12 - 2.5 vc
HF Transducer	inch	1 - 1.7 vc
Recommended Amplifier	W	600
Rated Long Term Power (IEC)	W	300
Rated Short Term Power (IEC)	W	1200
Rated Impedance	Ω	8
Transformer Taps	W	100 / 200
Frequency Response (@-6dB)	Hz	70 - 20.000
Sensitivity (@1W/1m)	dB	98
Max SPL (cont/peak)	dB	124 / 128
Nominal Dispersion	H° x V°	90 x 90
Materials		PE / Stainless Steel
Dimensions (WxHxD)	mm inch	430 x 430 x 400 16.92 x 16.92 x 15.74
Net weight	Kg Lb	18.2 40.12



SHADOW 108CT

Code		36193
Configuration	Way	2 coax
LF Transducer	inch	8 - 2 vc
HF Transducer	inch	1 - 1.4 vc
Recommended Amplifier	W	450
Rated Long Term Power (IEC)	W	225
Rated Short Term Power (IEC)	W	900
Rated Impedance	Ω	8
Transformer Taps	W	50 / 100
Frequency Response (@-6dB)	Hz	80 - 20.000
Sensitivity (@1W/1m)	dB	95
Max SPL (cont/peak)	dB	120 / 124
Nominal Dispersion	H° x V°	90 x 90
Materials		PE / Stainless Steel
Dimensions (WxHxD)	mm inch	285 x 285 x 250 11.22 x 11.22 x 9.84
Net weight	Kg Lb	10.5 23.14



SHADOW 105T

- Modern appearance combined with balanced sound reproduction
- Rugged IP55-rated enclosure
- Built-in die-cast aluminium wall bracket with ball/socket
- 7-core cable providing Hi-Z and Lo-Z power taps

Code		36192
Configuration	Way	2
LF Transducer	inch	5 - 1 vc
HF Transducer	inch	1 dome
Recommended Amplifier	W	120
Rated Long Term Power (IEC)	W	60
Rated Short Term Power (IEC)	W	240
Rated Impedance	Ω	8
Transformer Taps	W	15 / 25 / 40 / 50
Frequency Response (@-6dB)	Hz	90 - 20.000
Sensitivity (@1W/1m)	dB	89
Max SPL (cont/peak)	dB	109 / 112
Nominal Dispersion	H° x V°	100 x 100
Materials		PE / Stainless Steel
Dimensions (WxHxD)	mm	168 x 222 x 165
	inch	6.61 x 8.74 x 6.14
Net weight	Kg	3.1
	Lb	6.83



WATER RESISTANT GRILL

The exceptionally **weather-resistant driver** is further protected by a **water-resistant grille** that prevents the elements, solid or liquid, from getting inside the enclosure. Each protective grille is a **three-layer structure** that consists of an external perforated stainless steel panel treated with special protection, a centre layer of reticulated foam and an inner layer of water-repellent polyester mesh, providing maximum protection and minimal acoustical attenuation.

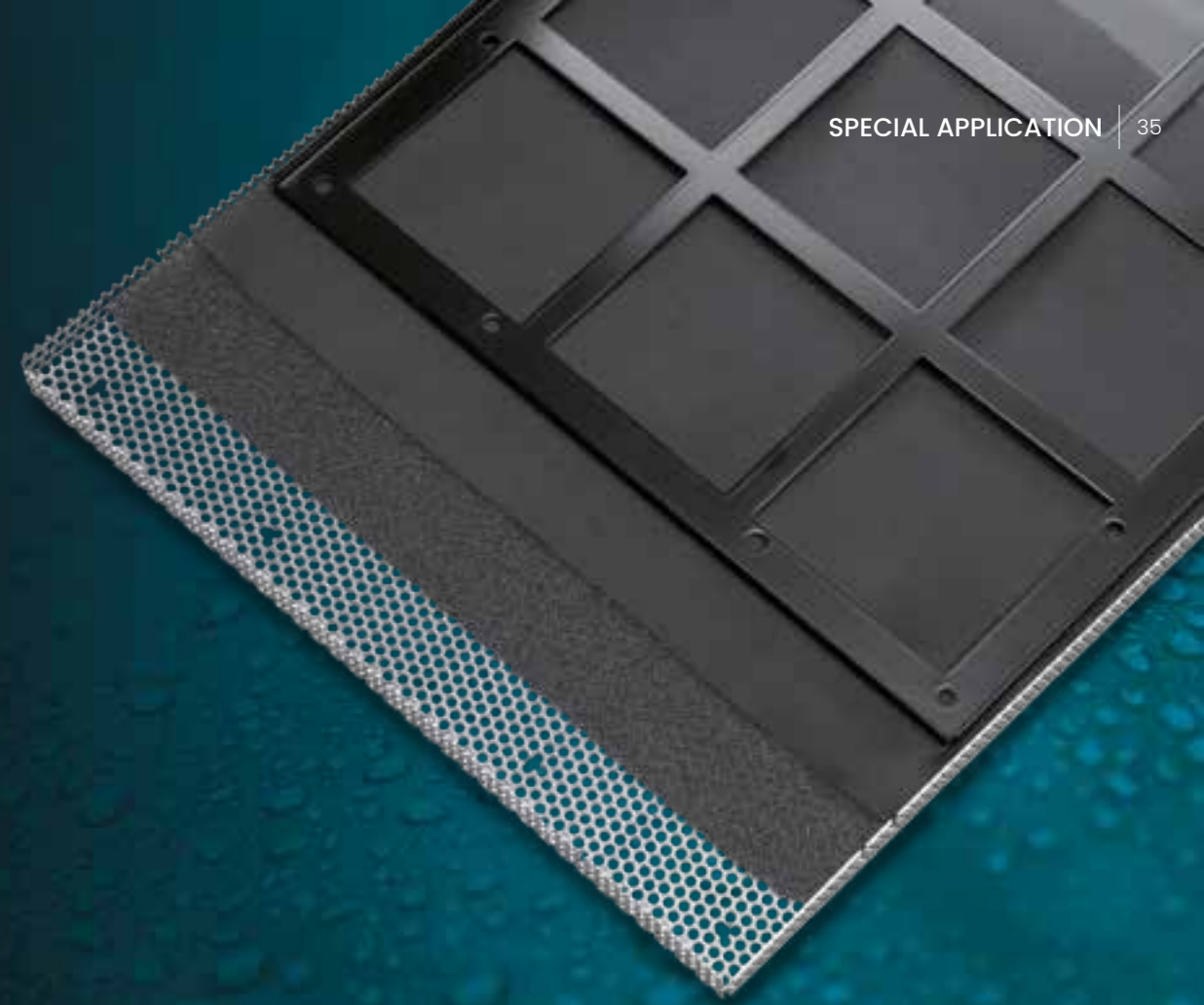

CIRCUITRY PROTECTION & ROTOMOLDED ENCLOSURES

All internal circuitry is **protected with a special sealing** and treated with weather proofing compound against the effects of moisture, corrosion and oxidation.

The loudspeaker cabinet is a **single-piece rotomolded enclosure** made from polyethylene, fully UV-protected and equipped with a stainless steel U-bracket for fixed installation. The **curved shape** helps to reduce acoustic reflections and standing waves within the enclosure for improved LF performance, while outdoors, the rounded shape inhibits standing water.

DUNE 660

This garden speaker is designed to blend easily into residential areas and outdoor facilities such as theme parks, hotels and resorts.

A **relaxing sound experience** is guaranteed by the **360° horizontal dispersion** pattern that this 6.5" 2-way speaker design provides.

The downward-firing speaker design and the **sturdy polyethylene enclosure** protects DUNE 660 from dust and water condensation.



DUNE 660

- Warm sound reproduction
- Waterproof
- 2-way speaker design
- 70V/100V or 8Ω multitap line transformer
- 360° outdoor coverage
- IP66-rated

Code (Brown - Green)		47048 / 47049
Configuration	way	2
LF transducer	inch	6.5
HF transducer	inch	1
Recommended Amplifier	W	120
Rated Long Term Power (IEC)	W	60
Rated Short Term Power (IEC)	W	240
Rated impedance	Ω	8
Transformer taps	W	60 - 30 - 15 / Bypass
Frequency response (@-10dB)	Hz	70 - 20.000
Sensitivity (@1W/1m)	dB	79
Max SPL (cont/peak)	dB	96 / 103
Nominal dispersion	H° x V°	Omni
Materials		ABS
Dimensions (WxHxD)	mm	330 x 552 x 270
	inch	12.99 x 21.73 x 10.62
Net weight	Kg	3.8
	Lb	8.38

CSP 610 TMG/EN

The construction and materials of this in-ceiling speaker make it suitable for **marine applications, indoor swimming pools** and **cleanroom applications** such as dust-sensitive manufacturing plants, laboratories, hospitals and testing facilities.

The flat design enclosure made from **high quality polypropylene** offers permanent protection from seawater and UV rays. The CSP is equipped with a 6.5" full-range loudspeaker.



CSP 610 TMG/EN

- Suitable for marine and cleanroom application
- Compact and lightweight enclosure
- Balanced sound reproduction
- PG9 in & thru entry cables connection
- 5-pin terminal connector

Code		45891
Configuration	way	1
Fullrange transducer	inch	6.5
Recommended Amplifier	W	---
Rated Long Term Power (IEC)	W	---
Rated Short Term Power (IEC)	W	---
Rated impedance	Ω	---
Transformer taps	W	10 / 6 / 3 / 1.5
Frequency response (@-6dB)	Hz	42 - 25.000
Sensitivity (@1W/1m)	dB	91
Max SPL (cont/peak)	dB	98.2 / 101.2
Nominal dispersion	H° x V°	145 conical
Materials		ABS
Dimensions (WxHxD)	mm inch	Ø220 x 76 Ø8.66 x 2.98
Net weight	Kg Lb	1 2.20

VERTUS CLA 112S

CLA 112S is the new **IP55 waterproof subwoofer**. The 12" down-firing excursion driver mounted in a clean and elegant cube-shaped aluminium cabinet provides **deep bass** reproduction.

Combines excellent acoustics with pleasing aesthetics.

This subwoofer blends uniquely into indoor and outdoor venues with a paint finish that can be customised in every colour.

KEY FEATURES

- Deep bass reproduction
- All-weather applications
- Custom finishes on request
- Terminal strip in & thru connector
- Ideal match for KEIRON, VERTUS CLA and SHADOW series
- IP55-rated



VERTUS CLA 112S

Code (Black / White)		46116 / 46115
Configuration	way	1
LF transducer	inch	12 - 2.5 vc
HF transducer	inch	---
Recommended Amplifier	W	600
Rated Long Term Power (IEC)	W	300
Rated Short Term Power (IEC)	W	1200
Rated impedance	Ω	8
Transformer taps	W	---
Frequency response (@-6dB)	Hz	40 - 300
Sensitivity (@1W/1m)	dB	96
Max SPL (cont/peak)	dB	127 / 130
Nominal dispersion	H° x V°	Omni
Materials		Aluminium
Dimensions (WxD)	mm	400 x 410 x 400
	inch	15.74 x 16.14 x 15.74
Net weight	Kg	25
	Lb	55.11



LIBRA 8S

This elegant new pendant subwoofer is constructed in **Baltic birch plywood** and can be supplied in **customised colours** and **wood finishes**.

The 8" down-firing excursion driver is mounted in a minimalistically designed enclosure. LIBRA 8S delivers **natural and warm sound**, wide coverage in mid/low-height venues and excellent low frequency response for background/foreground music applications.

The suspension system keeps hardware and connections out of sight. The perfect solution for environments with challenging wall reflections.

KEY FEATURES

- Natural low-frequency reproduction
- Compact cylindrical enclosure
- 8" excursion driver
- Bass reflex enclosure
- Custom finishes on request
- Euroblock in & thru connector
- Ideal match for LIBRA 5CT pendant speaker



LIBRA 8S

Code (Black / White)		46118 / 46117
Configuration	way	1
LF transducer	inch	8
HF transducer	inch	---
Recommended Amplifier	W	300
Rated Long Term Power (IEC)	W	150
Rated Short Term Power (IEC)	W	600
Rated impedance	Ω	8
Transformer taps	W	---
Frequency response (@-6dB)	Hz	42 - 300
Sensitivity (@1W/1m)	dB	89
Max SPL (cont/peak)	dB	114 / 117
Nominal dispersion	H° x V°	Omni
Materials		Baltic birch plywood / Steel
Dimensions (WxHxD)	mm inch	Ø326 x 27.4 Ø12.83 x 10.78
Net weight	Kg Lb	6.1 13.4



Examples of possible customizations according to availability



KEIRON 8S

Equipped with an 8" excursion driver in a vented enclosure and four **removable rubber feet** for ground stacking, the KEIRON 8S is a compact subwoofer suitable for **floor or wall mounting** with its dedicated bracket.

Made in plywood (HDF) with scratch-resistant paint finish, it can be customised in different colours upon request.

With its slim and clean design, KEIRON 8S is particularly suitable for integration in high-end projects.

KEY FEATURES

- Clear and warm low frequency reproduction
- Bass reflex enclosure
- Flexible installation features
- Custom finishes on request
- Euroblock in & thru connector
- Ideal match for KEIRON, VERTUS CLA and PROJECT series



KEIRON 8S

Code (Black / White)		46385 / 45175
Configuration	way	1
LF transducer	inch	8 - 1.5 vc
HF transducer	inch	---
Recommended Amplifier	W	300
Rated Long Term Power (IEC)	W	150
Rated Short Term Power (IEC)	W	600
Rated impedance	Ω	8
Transformer taps	W	---
Frequency response (@-6dB)	Hz	42 - 300
Sensitivity (@1W/1m)	dB	89
Max SPL (cont/peak)	dB	114 / 117
Nominal dispersion	H° x V°	Omni
Materials		HDF
Dimensions (WxD)	mm	390 x 190 x 390
	inch	15.35 x 6.06 x 15.35
Net weight	Kg	8
	Lb	17.64

Related accessories



KR-W 8S

Code: (Black / White): 45581 / 46182
Wall metal bracket for Keiron 8S



PROJECT 1020SA

PROJECT 1020SA is an extremely compact and **powerful 10" active subwoofer** designed to be a **plug-and-play** solution for cost-conscious installations.

This subwoofer features a 150W built-in amplifier, stereo inputs/outputs with low-cut regulation and master controls which include volume, crossover and phase regulations.

KEY FEATURES

- Warm bass reproduction
- XLR stereo outputs with low-cut frequency control
- Auto-standby switch mode
- Stereo XLR/TRS balanced - stereo RCA unbalanced inputs
- Bass reflex enclosure
- Unobtrusive textured finish
- 100 V/240 V~ 50/60 Hz switchable power input
- Ideal match for PROJECT and CSL series



PROJECT 1020SA

Code (Black / White)		44147 / 44222
Configuration	way	1
LF transducer	inch	10
HF transducer	inch	---
Built-in Amplifier	W	150
Rated Long Term Power (IEC)	W	---
Rated Short Term Power (IEC)	W	---
Input impedance	Ω	10 kΩ balanced / 20 k unbalanced
Transformer taps (@100V)	W	---
Frequency response (@-6dB)	Hz	40 - 150
Sensitivity (@1W/1m)	dB	---
Max SPL (cont/peak)	dB	110
Nominal dispersion	H° x V°	360
Materials		MDF
Dimensions (WxHxD)	mm inch	330 x 367 x 365 13 x 14.44 x 14.37
Net weight	Kg Lb	16 35

ELYSION 8ST

ELYSION 8S is an in-ceiling 8" subwoofer **designed to enhance bass performance** in different applications. The cabinet has a magnetic paintable front grille, a springlock mounting clamp, safety hook and front power switch.

ELYSION 8S is equipped with **line transformer for Hi-Z applications** and 5-pin ceramic terminal block with thermal fuse for connecting further speakers directly.

The standard front grille is available in black or white and can be customised in all colours.

KEY FEATURES

- Bass reflex enclosure
- Fast installation with springlock mounting clamps
- Paintable front grille
- Ideal match for ELYSION series



ELYSION 8ST

Code (Black / White)		47332 / 47333
Configuration	way	1
LF transducer	inch	8
HF transducer	inch	---
Recommended Amplifier	W	200
Rated Long Term Power (IEC)	W	100
Rated Short Term Power (IEC)	W	400
Rated impedance	Ω	8
Transformer taps (@100V)	W	60 / 30 / 15 / Bypass
Frequency response (@-6dB)	Hz	28 - 208
Sensitivity (@1W/1m)	dB	90
Max SPL (cont/peak)	dB	113 / 116
Nominal dispersion	H° x V°	360
Materials		Steel / Steel
Dimensions (WxHxD)	mm inch	Ø409 x 255 Ø16.1 x 10
Net weight	Kg Lb	10 22

SOP SERIES

The SOP series of high-efficiency sound projectors with a new 5.25" dual cone driver, is designed to provide **clear speech** and **background music** reproduction.

The discreet and elegant design is combined with a rugged, **IP66-rated ABS construction**. These sound projectors are the ideal choice for shopping centres, railway stations, parking areas, theme parks etc.

A **mono-directional** and a **bi-directional** model are each available in black or white with integrated junction box to facilitate quick and easy wiring.

KEY FEATURES

- IP66 junction box with in & thru connectors
- Ceramic terminal block
- Elegant modern design
- Highly reliable speaker design
- Rugged ABS body and coated aluminium grille



SOP 522T

Code (Black / White)		47324 / 47325
Configuration	way	1
Fullrange Transducer	inch	2 x 5.25
Recommended Amplifier	W	---
Long Term Power (cont)	W	---
Short Term Power (peak)	W	---
Rated Impedance	Ω	500 / 1000 / 2000
Transformer Taps (@100V)	W	20 / 10 / 5
Frequency Response (@-6dB)	Hz	50 - 18.000
Sensitivity (@1W/1m)	dB	90
Max SPL (cont/peak)	dB	103 / 109
Nominal Dispersion	H° x V°	2 x 90 conical
Materials		ABS / Aluminium
Dimensions (WxHxD)	mm inch	280 x 190 x 196 11 x 7.48 x 7.72
Net Weight	Kg Lb	2.67 5.89

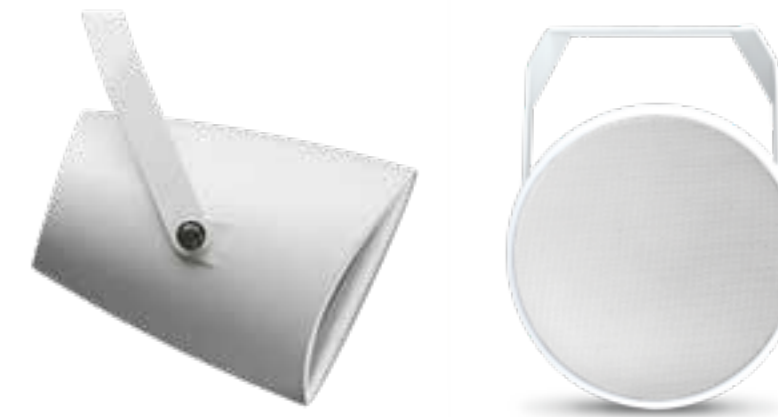

SOP 521T

Code (Black / White)		47326 / 47327
Configuration	way	1
Fullrange Transducer	inch	5.25
Recommended Amplifier	W	---
Long Term Power (cont)	W	---
Short Term Power (peak)	W	---
Rated Impedance	Ω	500 / 1000 / 2000
Transformer Taps (@100V)	W	20 / 10 / 5
Frequency Response (@-6dB)	Hz	50 - 18.000
Sensitivity (@1W/1m)	dB	90
Max SPL (cont/peak)	dB	103 / 109
Nominal Dispersion	H° x V°	90 conical
Materials		ABS / Aluminium
Dimensions (WxHxD)	mm inch	221 x 170 x 166 8.70 x 6.69 x 6.53
Net Weight	Kg Lb	1.56 3.44

HS SERIES

Both **MSH50T** and **HS50T** sound projectors feature a horn design, rugged, waterproof construction, high sensitivity and narrow sound dispersion across the vocal spectrum.

The 2-way MSH50T model provides an **extended frequency response** suitable for music and voice applications, indoors and outdoors, such as warehouses, car parks and swimming pools.

The HS50T's **aluminium horn speaker** is renowned for both **high reliability** and superb efficiency in **speech applications**, making it suitable for all industrial environments.

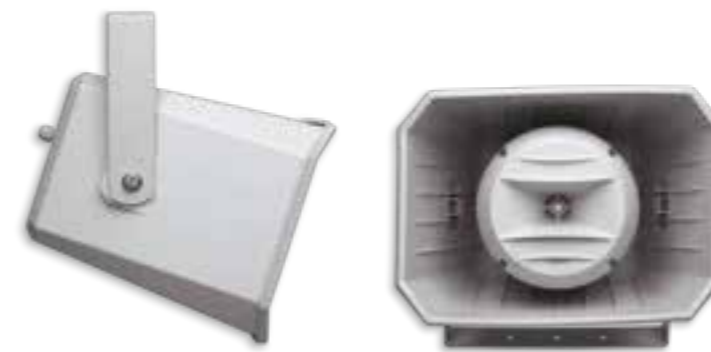

MSH 50T

- 2-way horn speaker system design
- Extended frequency response
- Stainless steel bracket
- Rugged ABS cabinet
- Waterproof termination junction box

Code		29431
Configuration	Way	2
LF Transducer	inch	6
HF Transducer	inch	1
Recommended Amplifier	W	100
Rated Long Term Power (IEC)	W	50
Rated Short Term Power (IEC)	W	200
Rated Impedance	Ω	8
Transformer Taps	W	50 / 25 / 12.5 / 9 / 4.5 / 3.5 / Bypass
Frequency Response (@-6dB)	Hz	90 - 20,000
Sensitivity (@1W/1m)	dB	99
Max SPL (cont/peak)	dB	119 / 122
Nominal Dispersion	H° x V°	70 x 30
Materials		ABS / Steel
Dimensions (WxHxD)	mm	362 x 315 x 300
	inch	14.52 x 12.40 x 11.81
Net Weight	Kg	3.9
	Lb	8.6



HS 50T

- Aluminium horn with durable powder coating
- Highly reliable horn speaker design
- High SPL performance
- Stainless steel bracket
- Rotary power selector

Code		29422
Configuration	Way	1
Fullrange Transducer	inch	---
Recommended Amplifier	W	---
Rated Long Term Power (IEC)	W	---
Rated Short Term Power (IEC)	W	---
Rated Impedance	Ω	---
Transformer Taps	W	50 / 25
Frequency Response (@-6dB)	Hz	380 - 6,500
Sensitivity (@1W/1m)	dB	109
Max SPL (cont/peak)	dB	129 / 132
Nominal Dispersion	H° x V°	60 conical
Materials		Aluminium / Steel
Dimensions (WxHxD)	mm	Ø325 x 350
	inch	Ø12.79 x 13.77
Net Weight	Kg	2.58
	Lb	5.67

W SERIES

This surface-mounted series offers **quick and easy installation, saving time and costs.**

Ideally suited to applications ranging from offices to educational buildings where clear announcements and occasional background music is needed.

WCS 650 is equipped with a 10W 6.5" full-range driver housed in an ABS cabinet, while **WSH 1006** is equipped with a 6W 5.5" full-range driver housed in an ABS cabinet with powder-coated iron mesh grille.



WCS 650

- Recommended for on-ceiling and on-wall installation
- Springlock mounting clamp
- Very lightweight cabinet
- Cost-effective

Code		29470
Configuration	way	1
Fullrange Transducer	inch	6.5
Recommended Amplifier	W	---
Rated Long Term Power (IEC)	W	---
Rated Short Term Power (IEC)	W	---
Rated Impedance	Ω	---
Transformer Taps	W	10 / 5 / 2.5
Frequency Response (@-6dB)	Hz	120 - 18.000
Sensitivity (@1W/1m)	dB	93
Max SPL (cont/peak)	dB	103 / 106
Nominal Dispersion	H° x V°	150 conical
Materials		ABS
Dimensions (WxHxD)	mm inch	Ø265 x 85 Ø10.43 x 3.34
Net Weight	Kg Lb	1.2 2.64



WSH 1006

- Recommended for on-wall installation
- Hidden screw mounting
- High sensitivity level
- Cost-effective

Code		29419
Configuration	way	1
Fullrange Transducer	inch	5.5
Recommended Amplifier	W	---
Rated Long Term Power (IEC)	W	---
Rated Short Term Power (IEC)	W	---
Rated Impedance	Ω	---
Transformer Taps	W	6 / 3
Frequency Response (@-6dB)	Hz	150 - 15.000
Sensitivity (@1W/1m)	dB	98
Max SPL (cont/peak)	dB	106 / 109
Nominal Dispersion	H° x V°	120 conical
Materials		ABS / Metal
Dimensions (WxHxD)	mm inch	210 x 320 x 85 8.26 x 12.59 x 3.34
Net Weight	Kg Lb	1.21 2.66



POWER AMPLIFIERS

56 DIGITAL

60 ANALOG

MDA SERIES

The MDA 4000 series of power amplifiers combines a full **4x4 matrix** with DSP in a flexible **class D** platform.

From small-to-medium-scale installations, MDA amplifiers are a perfect fit for different types of multi-zone applications, either in **standalone** mode or **integrated into a complex audio system**.

This compact series offers **three 4-channel models** with a total power **from 500W to 3000W** in either Hi-Z or Low-Z output configuration. The MDA series meets the requirements of all speaker systems, offering a dynamic, satisfying listening experience.

All models offer multiple **analogue and digital input options**, built-in wireless access points, wired LAN connection and programmable inputs that can be used for remote control.

KEY FEATURES

- Highly reliable 4-channel class D power amplifier
- Flexible Hi-Z and Lo-Z speaker output configuration
- In/Out S/PDIF features facilitates easy system extension
- Remote control through integrated WiFi access point or Ethernet port
- Intuitive browser-based user interface offering full control
- Speaker preset libraries reduce system setup time
- 8-pin GPIO interface adds standard remote control features
- Class-leading Energy Star® rating



MDA 4800

Code		46066
Channels		4x Lo-Z / 2x Hi-Z
Amplifier Topology		Class D
Lo-Z Output Power	W	4 x 750W - 4 Ω
Hi-Z Output Power	W	2 x 1500W - 100V
Audio Inputs		4 x line / 1 x SPDIF
On board sources		Noise generator
Audio Outputs		1 x SPDIF
GPIO (Control IN/OUT)		8-pin
Controls		Web Browser
Frequency Response	Hz	20 - 20.000
S/N Ratio	dB	>106
THD + N	%	<0.05
Power Supply	V	100 - 240 (50Hz - 60Hz)
Power Consumption (@230V)	W	700
Dimensions (WxHxD)	mm inch	440 x 88 x 320 17.32 x 3.46 x 12.59
Net Weight	Kg Lb	7.4 16.31



MDA 4500

Code		46065
Channels		4x Lo-Z / 2x Hi-Z
Amplifier Topology		Class D
Lo-Z Output Power	W	4 x 500W - 4 Ω
Hi-Z Output Power	W	2 x 1000W - 100V
Audio Inputs		4 x line / 1 x SPDIF
On board sources		Noise generator
Audio Outputs		1 x SPDIF
GPIO (Control IN/OUT)		8-pin
Controls		Web Browser
Frequency Response	Hz	20 - 20.000
S/N Ratio	dB	>106
THD + N	%	<0.05
Power Supply	V	100 - 240 (50Hz - 60Hz)
Power Consumption (@230V)	W	700
Dimensions (WxHxD)	mm inch	440 x 88 x 320 17.32 x 3.46 x 12.59
Net Weight	Kg Lb	7.4 16.31



MDA 4125

Code		46064
Channels		4 x Lo-Z / 2 x Hi-Z
Amplifier Topology		Class D
Lo-Z Output Power	W	4 x 125W - 4 Ω
Hi-Z Output Power	W	2 x 250W - 100V
Audio Inputs		4 x line / 1 x SPDIF
On board sources		Noise generator
Audio Outputs		1 x SPDIF
GPIO (Control IN/OUT)		8-pin
Controls		Web browser
Frequency Response	Hz	20 - 20.000
S/N Ratio	dB	>106
THD + N	%	<0.05
Power Supply	V	100 - 240 (50Hz - 60Hz)
Power Consumption (@230V)	W	150
Dimensions (WxHxD)	mm	220 x 44 x 320
	inch	8.66 x 1.73 x 12.59
Net Weight	Kg	2.2
	Lb	4.85

Related accessories

-  **MDA-WM**
Code: 46067
Wall mount kit for MDA 4125
-  **MDA-RM**
Code: 460678
Rack mount kit for MDA 4125



CONNECT, set up
and **MANAGE**

Any smartphone, tablet or PC can access the **intuitive interface** directly via a **web browser**, making it easy to control, configure and monitor the amplifier. **Custom speaker libraries** provide installers with a **quick and fluid workflow configuration**.

MPA 5480 / 5240 / 5120



MPA SERIES

This range of power units is specifically designed for broadcast and background music applications. Reliability, minimal design and robust structure combine in the MPA Series to provide an ideal solution for quality amplification at a **cost-effective price point**. Available in three power ratings, **120W, 240W and 480W**, all run at Hi-Z or Low-Z, ensuring consistent quality. The front panel gives access to basic tone and level controls. When used in **emergency situations**, all the front-panel (tone and level) controls can be disabled to prevent accidental changes to the original setting, ensuring higher levels of security. A simple, affordable management solution.

KEY FEATURES

- Operation on AC or DC 24V to suit all installation requirements
- 100/70/50V line or 8Ω speaker outputs
- Deactivatable front panel control for emergency situations
- Easy connection to MBT 1101 paging stations
- 2U 19"

		MPA 5480	MPA 5240	MPA 5120
Code		37491	37489	37490
Channels		1 x Lo-Z / 1 x Hi-Z	1 x Lo-Z / 1 x Hi-Z	1 x Lo-Z / 1 x Hi-Z
Amplifier Topology		Class AB	Class AB	Class AB
Lo-Z Output Power	W	1 x 480W - 8 Ω	1 x 240W - 8 Ω	1 x 120W - 8 Ω
Hi-Z Output Power	W	1 x 480W - 100V	1 x 240W - 100V	1 x 120W - 100V
Audio Inputs		1 x line / 1 x mic (RJ45) / 1 x Emg/Tel		
On board sources		---	---	---
Audio Outputs		1 x line	1 x line	1 x line
GPIO (Control IN/OUT)		1 x precedence	1 x precedence	1 x precedence
Controls		Front panel	Front panel	Front panel
Frequency Response	Hz	30 - 20.000	30 - 20.000	30 - 20.000
S/N Ratio	dB	>75	>75	>75
THD + N	%	<1	<1	<1
Power Supply	V	115 (50Hz-60Hz) / 230 (50Hz-60Hz)		
Power Consumption (@230V)	W	1160 (@230VAC)	535 (@230VAC)	280 (@230VAC)
Dimensions (WxHxD)	mm inch	432 x 88 x 272 17 x 3.46 x 10.70	432 x 88 x 272 17 x 3.46 x 10.70	432 x 88 x 272 17 x 3.46 x 10.70
Net Weight	Kg Lb	16 35.3	11.6 25.57	8.6 18.95

Related accessories



RMK-5000

Code: 18016
Rack mount brackets

MXA 1120 / 1060



MXA SERIES

These integrated mixer-amplifiers provide the perfect balance of **flexibility, functionality** and **affordability**, combining basic mixer functionalities with a robust single-channel power amplification board. Engineered for versatility and cost-effectiveness, the MXA series is composed of two models with a total power of **60W or 120W** in either Hi-Z or Low-Z output configuration. With multiple mic/line inputs, programme selection, basic tones and level management, these amplifiers are designed to adapt to a variety of audio needs, from basic **background music** distribution to **paging or emergency** purposes. The clean front panel displaying essential controls only makes these amplifiers **very intuitive to manage**; each input channel has a dedicated volume control while the main control handles master volume, bass and treble and power switch.

KEY FEATURES

- Wide range of mic and line inputs
- Available phantom power on mic inputs
- Inputs priority and settings by micro-switches
- 100/70/50V line or 8Ω speaker outputs
- Easy connection to MBT 1101 paging stations
- 2U 19"

		MXA 1120	MXA 1060
Code		37639	37638
Channels		1 x Lo-Z / 1 x Hi-Z	1 x Lo-Z / 1 x Hi-Z
Amplifier Topology		Class AB	Class AB
Lo-Z Output Power	W	1 x 120W - 8 Ω	1 x 60W - 8 Ω
Hi-Z Output Power	W	1 x 120W - 100V	1 x 60W - 100V
Audio Inputs		2 x mic (1 x VOX) - 1 x mic (RJ45) - 1 x mic/line - 2 x aux - 1 x Emg/Tel	
On board sources		---	---
Audio Outputs		1 x line	1 x line
GPIO (Control IN/OUT)		1 x precedence	1 x precedence
Controls		Front panel	Front panel
Frequency Response	Hz	40 - 20.000	40 - 20.000
S/N Ratio	dB	Mic: 66dB / line: 75dB	
THD + N	%	<1	<1
Power Supply	V	120 - 230 (50Hz - 60Hz)	
Power Consumption (@230V)	W	270	130
Dimension (WxHxD)	mm inch	432 x 88 x 234 17 x 3.46 x 9.21	432 x 88 x 234 17 x 3.46 x 9.21
Net Weight	Kg Lb	9 19.8	6.5 14.33

Related accessories



RMK-5000

Code: 18016
Rack mount brackets

MDS 1240 / 1120 / 1060**MDS SERIES**

The MDS series of integrated amplifiers combines all you need for a quick and easy setup in a compact metal chassis. This is the ideal audio solution for any retail store or cafe that needs an intuitive operating system **with no software** or complicated configuration. **Three single-channel** amplifier models from **60W, 120W** and **240W** are all equipped with four mic/line inputs and one line output, an MP3 player and an FM tuner module. The speaker output is compatible with Lo-Z or Hi-Z power distribution.

KEY FEATURES

- Built-in music sources: USB, SD/MMC and FM radio
- User-friendly front panel for easy operation
- Wide range of mic and line inputs
- Phantom power available on mic inputs
- In/out connectors to external audio processor
- 100/70/50V line or 4Ω speaker outputs

- 2U 19"

		MDS 1240	MDS 1120	MDS 1060
Code		37497	37496	37495
Channels		1 x Lo-Z / 1 x Hi-Z	1 x Lo-Z / 1 x Hi-Z	1 x Lo-Z / 1 x Hi-Z
Amplifier Topology		Class AB	Class AB	Class AB
Lo-Z Output Power	W	1 x 240W - 4 Ω	1 x 120W - 4 Ω	1 x 60W - 4 Ω
Hi-Z Output Power	W	1 x 240W - 100V	1 x 120W - 100V	1 x 60W - 100V
Audio Inputs		3 x mic/line - 1 x aux	3 x mic/line - 1 x aux	3 x mic/line - 1 x aux
On Board Sources		USB - SD - FM	USB - SD - FM	USB - SD - FM
Audio Outputs		1 x line	1 x line	1 x line
GPIO (Control IN/OUT)		1 x precedence	1 x precedence	1 x precedence
Controls		Front panel	Front panel	Front panel
Frequency Response	Hz	30 - 18.000	30 - 18.000	30 - 18.000
S/N Ratio	dB	80	80	78
THD + N	%	<1	<1	<1
Power Supply	V	120 - 230 (50Hz - 60Hz)	120 - 230 (50Hz - 60Hz)	120 - 230 (50Hz - 60Hz)
Power Consumption (@230V)	W	600	300	150
Dimensions (WxHxD)	mm inch	432 x 88 x 270 17 x 3.46 x 10.62	432 x 88 x 270 17 x 3.46 x 10.62	432 x 88 x 270 17 x 3.46 x 10.62
Net Weight	Kg Lb	10.5 23.15	8.5 18.73	6.2 13.66

Related accessories

RMK-5000
Code: 18016
Rack mount brackets

AM 5040**AM 5040**

At 40W, this is the smallest of our mixer amplifiers. Particularly suitable for **small installations**, a variety of inputs and outputs offer considerable **flexibility**. The two microphone inputs on the back and the front panel offer **VOX priority**. Additionally, two inputs for sound sources are selectable via the front panel and an audio input for emergency or telephone provides VOX function.

KEY FEATURES

- Compact and lightweight design
- Flexible mic and line input connections
- Balanced mic input (with VOX function) on front panel
- 100/70/50V line or 8Ω speaker outputs
- Operation on AC or DC 24V to suit all installation requirements

Code		43767
Channels		1 x Lo-Z / 1 x Hi-Z
Amplifier Topology		Class AB
Lo-Z Output Power	W	1 x 40W - 8 Ω
Hi-Z Output Power	W	1x 40W - 100V
Audio Inputs		2 x mic (1 x VOX) - 2 x aux - 1 x Emg/Tel (VOX)
On board sources		---
Audio Outputs		1 x line
GPIO (Control IN/OUT)		1 x precedence
Controls		Front panel
Frequency Response	Hz	35 - 20.000
S/N Ratio	dB	>61
THD + N	%	<1
Power Supply	V	115 - 230 (50Hz - 60Hz)
Power Consumption (@230V)	W	100
Dimensions (WxHxD)	mm inch	275 x 88 x 230 10.82 x 3.46 x 9.05
Net Weight	Kg Lb	4.2 9.26



CONTROL SYSTEMS

- 66 DIGITAL MATRIX
- 68 DIGITAL MIXER
- 69 ANALOG MIXER

DM-8208

The DM-8208 Digital Matrix System is designed to be **flexible, powerful** and **easy to configure**, install and manage.

With audio quality tailored for a wide range of applications including background/foreground and paging, the DM-8208 Digital Matrix System provides **complete control** over audio configuration and signal processing.

Basic user controls such as volume and source selection within a zone can be easily operated via the wall-mounted DM-P8208 panel controller.

More advanced users requiring multiple zone control can use the Graphical User Interface (GUI) for PC or smart devices.

The DM-C8208 can be controlled via Ethernet for easy integration with a wide range of building management and control systems. With the DM-S8208 remote paging station, users can select parts of the desired zone or the entire area to broadcast live calls and local music sources.



DM-S8208

Paging Station

- User-friendly interface for easy operation
- Local music input with volume control
- Switches for priority and chime configuration
- Each DM-C8208 can control up to eight paging stations.

Code		45810
Mic inputs		XLR connector
Audio Outputs		3.5mm jack
Frequency Response	Hz	Mic: 100 – 15,000 / aux: 20 – 20,000
S/N Ratio	dB	Mic >50 – aux >80
THD + N	%	Mic < 0.5 – aux <0.2
Microphone type		Cardioid - Electret
Indicators		Leds
Controls		Keyboard
Paging Port		2 x RJ45
Protocol		RS-485
Power Supply	V	24 (DC) 500mA (from DM-C8208 or external)
Power Consumption (@24VDC)	W	12
Dimensions (WxHxD)	mm inch	264 x 135 x 62 10.45 x 5.3 x 2.4
Net Weight	Kg Lb	1 2.2



DM-P8208

Wall Panel

- Aesthetic compact design
- One-zone volume and programme selection
- Can be daisy-chained through LINK RJ45 terminal
- Each DM-C8208 can control up to eight wall panels

Code		45809
Display		LCD
Controls		Rotary encoder / push button
Control Protocol		RS-485
Port		2 x RJ45
Power Supply	V	24VDC (by DM-C8208)
Power Consumption (@24VDC)	W	0.5
Dimensions (WxHxD)	mm inch	115 x 78 x 17 4.5 x 3.1 x 0.7
Net Weight	Kg Lb	0.1 0.22



DM-C8208

Digital Matrix

- Multi-purpose 8-channel DSP matrix controller for simple day-to-day management
- Flexible, customised remote control via PC, smartphone or wall panel using GPIO
- Eight balanced mic/line inputs with Phantom power
- Priority paging features available when using DM-S8208

Code		45808
Audio Inputs		8 x mic/line
Audio Outputs		8 x line
Frequency Response	Hz	20 – 20,000
S/N Ratio	dN	>80
THD + N	%	<0.01
Crosstalk	dB	>80
GPIO (Control IN/OUT)		12 IN – 6 OUT
Controls		Software / App
Paging Port		2 x RJ45
Panels Port		1 x RJ45
Power Supply	V	100 – 240V (50Hz – 60Hz) 24VDC
Power Consumption (@230V)	W	45
Dimensions (WxHxD)	mm inch	482 x 44 x 300 19 x 1.7 x 11.8
Net Weight	Kg Lb	3.5 7.71



WP 8008

Wall panel for DMM 8008

- Two available working modes: master and zone
- Intuitive front panel controls managing
- Provides lock and stand-by features
- Requires 12VDC external power supply

Code		38929
Display		LCD
Controls		Rotary ecoder with push button
Control Protocol		RS-485
Port		Phoenix connectors
Power Supply		12VDC (150mA)
Power Consumption (@230V)	V	0.5
Net Weight	Kg	0.27
	Lb	0.59

DMM 8008

Specially designed for commercial and professional applications such as conference rooms, auditoriums and entertainment venues, the DMM 8008 is a professional multi-application **Digital Matrix/Mixer** with independent configurable balanced mic/line inputs, balanced line outputs and logic controls. The communication between inputs and outputs in the matrix is ideal for **multi-zone applications** where the WP 8008 remote panel provides **dual control function** for single or global zones. The Automixing function automatically adjusts input levels to facilitate operation using NOM or Gain sharing. The **powerful DSP** offers parametric EQ, crossover filters, compressor section and peak limiter, phase and delay control and eight in/out logic ports. Every input has priority level selection for management of emergency announcements and microphone signals. Eight knobs on the front panel allow sensitive mic input adjustments, while **PC software** (supplied) allows configuration via TCP/IP or USB connection.

KEY FEATURES

- Full-featured DSP capabilities with excellent audio performance
- Remote control via PC, wall panel or custom third-party devices
- Front panel and GPIO controls simple day-to-day management
- Automixing features optimised for conferencing and speech applications

Code		38885
Audio Inputs		8 x mic/line
Audio Outputs		8 x Line
Frequency Response	Hz	20 - 20.000
S/N Ratio	dB	> 104
THD + N	%	< 0.005
Crosstalk	dB	> 80
GPIO (Control IN/OUT)		4 in / 4 out
Controls		Software
Paging Port		---
Panels Port		2 x RJ45
Power Supply	V	90 - 240V (50Hz - 60Hz)
Power Consumption (@230V)	W	40
Dimensions (WxHxD)	mm	482 x 44 x 229
	inch	18.97 x 1.73 x 9
Net Weight	Kg	3.5
	Lb	7.71



M12X4

The M12X4 **12-channel stereo mixer** is ideal for compact installations and schools, shops, restaurants, houses of worship and other venues looking for a **user-friendly interface**. It features four mic/line inputs with priority control over four stereo music inputs, two stereo outputs with dedicated volume controls plus one stereo output for recording. Microphone inputs provide phantom power and voice control to adjust speech intelligibility.

KEY FEATURES

- Low-distortion mic preamp with high dynamic range
- Flexible input connector plugs
- Priority switches on mic/line mono inputs
- Left/right output channels with independent volume control

Code		18147
Mono Mic / Line Inputs		4 x combo (XLR / 6.3mm Jack)
Stereo Line Inputs		8 x RCA (stereo)
Line Outputs	W	2 x XLR-M + 2 x RCA (stereo)
Recording Output	W	2 x RCA (stereo)
Frequency Response	Hz	20 - 20.000
S/N Ratio	dB	> 90
THD + N	%	< 0.025
Impedance	kΩ	2.2 (mic in) - 33 (line in) - 22 (stereo in)
Phantom Power	VDC	24
Max Output Level	dB	22
Indicators	%	LEDS
Controls		Front / Rear Panel
Power Supply	V	100 - 240V (50Hz - 60Hz)
Power Consumption (@230V)	W	15
Dimensions (WxHxD)	mm	482 x 44 x 229
	inch	18.97 x 1.73 x 9
Net Weight	Kg	2.4
	Lb	5.29



MUSIC SOURCES

72 AUDIO STREAMER

73 DUAL CHANNEL PLAYER

4WAVE

4WAVE is a **wireless streaming preamplifier** with network, LAN and Bluetooth 5.0 connectivity.

Connecting 4WAVE to an existing stereo system will enable music streaming from **smart devices**, USB, NAS or streaming services such as Spotify, Tidal and Qobuz in high resolution via the 4STREAM app, AirPlay, Bluetooth or other third-party-compatible apps.

4WAVE supports high-quality music streaming in sample rates up to 24bit 192kHz and supports lossless audio formats such as FLAC, APE and WAV. By adding more units you can set up a **wireless multiroom** or **multizone** audio system for the whole house for a great new way to enjoy music.

KEY FEATURES

- Managed through 4STREAM app
- Access to most leading streaming services, including internet radio
- WiFi and Ethernet network connectivity
- Built-in Bluetooth
- Linkable to other 4WAVE devices for source sharing
- Versatile in/out connections including aux in/out and USB
- IR remote control



Spotify connect



Wireless



AirPlay



Multi-Room



4WAVE

Code		47245
Connectivity		WAP - ETH - BT - USB
Audio Inputs		1 x aux
Audio Outputs		1 x aux
Frequency Response	Hz	20 - 20.000
S/N Ratio	dB	>91
THD + N	%	<0.03
Controls		App / Remote
Indicators		Led lights
Protocols		AirPlay, DLNA, UpnP, Spotify Connect, Uplay
Frequency Sampling		Up to 24bit / 192 KHz
Audio Format		FLAC / MP3 / AAC / AAC+ / ALAC / APE / WAV
Power Supply	V	5VDC - 1A
Dimensions (WxHxD)	mm	116 x 22.6 x 64
	inch	4.57 x 0.98 x 2.52
Net Weight	Kg	0.2
	Lb	0.44

MS02CD3/T

The MS02CD3/T **dual-channel player** combines different sources in a small 1U 19-inch housing, perfect for fixed installations such as pubs, shops, hotels, restaurants and shopping malls.

Sound can be played back from audio CDs, SD memory cards, MP3 from USB and AM/FM radio. Controls are accessible from the front panel with LCD display or the remote control (included). Two fixed stereo RCA outputs are provided.

Perfect for **multizone installations** such as FM radio and media/CD player can operate simultaneously, sending different sources to separate outputs.

KEY FEATURES

- Two independent stereo outputs (multimedia CD and AM/FM radio)
- Plays CD, CD-R, CD-R/W, USB, SD/MMC card and AM/FM radio
- Flexible source control from front panel or IR remote
- 1U 19" standard rackmount format



MS02CD3/T

Code		27867
Audio Inputs		USB Port - SD/MMC card slot - CD port for disk
Tuner Receiving Frequency	MHz	87.5 - 108
Line Outputs		4 x RCA (stereo CD + FM sections)
Frequency Response	Hz	20 - 20.000
S/N Ratio	dB	>70
THD + N	%	<0.1
Output Level	dBV	0
Indicators		2 x LCD + LEDS
Controls		Front panel + IR Remote
Power Supply	V	230 (50Hz - 60Hz)
Power Consumption (@230V)	W	50
Dimensions (WxHxD)	mm	482 x 44 x 250
	inch	18.97 x 1.73 x 9.84
Net Weight	Kg	3.5
	Lb	7.71



CONFERENCE SYSTEMS

76 WIRELESS

78 WIRED

CS4000

This **wireless conference system** incorporating the **latest technology** is an ideal choice for town halls, local business centres and courtrooms.

Designed to be user-friendly, provide reliable, clear and intelligible communication and maximise compatible channels within a given bandwidth, the CS4000 is composed of the **CSU4000 receiver**, the **CST4000 transmitter** and dedicated accessories.

The built-in logic circuit provides conferencing features. This user-friendly system simplifies meetings and is also an ideal solution for rental companies for their day-to-day mobile setups.



CST4000-CH1 / CH12

- Charging time depends on condition of rechargeable batteries used
- Battery status LED
- Protection against overload, short circuit and deep discharge

Code		45880 / 45881 + 45882
System		Charging station units
Slots		1 / 12
Charging Time	H	≈ 5h (2000mAh rechargeable battery)
Charging Voltage	VDC	12
Indicators		LEDS
Power Supply	V	100 - 240 (50Hz - 60Hz)
Power Consumption (@230V)	W	---
Weight	Kg	CST4000-CH1 0.2/0.44
	Lb	CST4000-CH12 3.8/8.37



CSU4000

- Up to 10 CSU4000 can be easily cascaded without additional splitter
- REMOSET technology for receiver/transmitter synchronisation
- Power supply for optional antenna booster
- Conference modes: override, priority and open mode

Code		45878
System		4-channel diversity UHF PLL wideband receiver
Frequency Range	MHz	470 - 694
Frequency Response	Hz	80 - 16.000
S/N Ratio	dB	> 105dB
THD + N		< 0.6 @1KHz
Audio Inputs		1 x Link (8-pin mini-DIN)
Audio Outputs		1 x Link (8-pin mini-DIN) / 4 x CHANNELS (XLR-M) 1 x Mix (XLR-M) / 1x Mix (6.3mm Jack)
Antenna IN/OUT		2 x BNC (+ DC12V/100mA) / 2x Link
Voltage Outputs		5-pin / + 5VDC
Indicators		LCD + LEDES
Controls		Front Panels
Mounting		Stand alone / 19" rack
Power Supply		100 - 240 (50Hz-60Hz)
Power Consumption (@230V)		20
Dimensions (WxHxD)	mm	485 x 45 x 260
	inch	19.09 x 1.77 x 10.23
Weight	Kg	2.4
	Lb	5.29



CST4000

- 15.74" removable gooseneck
- LCD display for group/channel, audio level and battery status
- Switchable power transmission
- Priority function for chairman
- Automatic switch-off

Code		45879
System		UHF PLL microphone console transmitter
Frequency range	MHz	470 - 694
Frequency response	Hz	60 - 16.000
Microphone Type		Super-cardioid Electret Condenser
Microphone Length	mm	400
Transmitting Power	mW	10 / 50
Operating Time	H	≈ 25
Mic Input Connector		4-pole mini XLR
Indicators		LCD + LEDES
Controls		Front Panel
Power Supply		UM3, AA x 2 (Supported rechargeable type)
Power Consumption (@230V)		---
Weight	Kg	0.72
	Lb	1.58

CS2000

The **CS2000 wired conference system** has been designed for ease-of-use, offering reliable, clear and intelligible communication to significantly enhance the meeting experience. It consists of the **CSU2000 control unit**, the **CSD2000 delegate microphone unit**, the **CSC2000 chairman microphone unit** and dedicated accessories.

This wired conference system is equipped with intelligent automatic mixing technology, providing a turnkey solution for quick, **plug-and-play** installation.

It is ideal for small-to-medium-scale meetings that seek versatility in a **cost-effective** solution for town halls, local business centres and courtrooms.



CSU2000

- Manages up to 50 delegate/chairman units (up to 150 when using EXS-1 and EXM-1 extender boards)
- Built-in MP3 recording function via USB memory stick
- Built-in monitor speaker system
- LCD display for setting and displaying mode status
- Easy day-to-day operation

Code		45887
System		Control unit with recording
Frequency Response	Hz	35 - 20.000
S/N Ratio	dB	> 70dB (A)
THD + N	%	< 0.06 @1kHz
Audio Inputs		1 x Tel (RCA) - 1 x insert (RCA) 1 x Rec (RCA) - 1 x line (RCA) 1 x .mic (XLR-F)
Audio Outputs		1 x Tel (RCA) - 1 x insert (RCA) 1 x Rec (RCA) - 1 x line (RCA) 1 x Headphone (3.5mm Jack)
Delegate / Chairman connectors		2 x 7-pole DIN
Recording		USB3.0 32GByte
Indicators		LCD + LEDs
Controls		Front Panels
Mounting		Stand alone
Power Supply	V	100 - 240 (50Hz - 60Hz)
Power Consumption (@230V)	W	90
Dimensions (WxD)	mm	360 x 90 x 150
	inch	14.17 x 3.54 x 5.90
Weight	Kg	1.8
	Lb	3.96



CSC2000 / CSD2000

- Cost-effective installation
- Mic on/off light ring
- Built-in monitor speaker system
- Priority button
- Easy day-to-day operation

Code (CSC2000 / CSD2000)		45888 / 45889
System		Chairman / Delegate microphone unit
Microphone type		Cardioid Electret Condenser
Frequency response (Mic)	Hz	50 - 18.000
Max SPL	dB	125
Gooseneck length	mm	400
Input Connector		1 x 2 m connection cable with 7-pole DIN plug (male)
Output Connector		1 x 7-pole DIN jack (female)
Headphone Outputs		2 x 3.5mm jack with volume control
Indicators		LEDs
Controls		Microphone on/off push-button, priority button (Only chairman version)
Power Supply	V	By CSU2000
Power Consumption (@230V)	W	---
Weight	Kg	1.2
	Lb	2.64

Related accessories



EXS-1
Code: 37647
Expansion kit slave



EXM-1
Code: 37646
Expansion kit master



UHF MICROPHONE SYSTEMS

82 U9000

84 U8000

86 ACCESSORIES

U9000

The U9000 system is the newest generation of **quad multi-channel wireless technology**, offering scalability and reliability combined with easy installation.

Designed for professional applications and for anyone requiring high performance in a small space. Consisting of the DRU9004, THU9000, TBU9000 and ABU9000 models, this series offers a range of **options to meet the needs of any application**, no matter how demanding they may be.

The U9000 system is designed to make your business operations **easier and more efficient**. It comes in **both single- and dual-channel versions** and boasts unparalleled performance and reliability.



DRU9004

- Ultra-compact 4-channel receiver in a 1U 19-inch rackmount format
- RF and mains voltage output for easy cascading
- Power supply for optional antenna booster
- Auto-scan function
- Switchable mic/line for single and mixed outputs

Code		45883
System		4-channel diversity UHF PLL wideband receiver
Frequency Range	MHz	470 - 694
Frequency Response	Hz	50 - 18.000
S/N Ratio	dB	> 106dB
THD + N	%	< 0.5 @1KHz
Audio Outputs		4 x CHANNELS (XLR-M) - 1 x MIX (XLR-M) - 1 x MIX (6.3mm Jack)
Antenna IN/OUT		2 x BNC (+ DC12V/100mA) + 2 x LINK
Indicators		LCD + LEDs
Controls		Front Panels
Mounting		Stand alone / 19" rack
Power Supply	V	100 - 240 (50Hz - 60Hz)
Power Consumption (@230V)	W	30
Dimensions (WxHxD)	mm	485 x 45 x 260
	inch	19.09 x 1.77 x 10.23
Weight	Kg	3
	Lb	6.61



THU9000

- Aluminium alloy chassis
- REMOSET technology for receiver/transmitter synchronisation
- Lock and mute functions
- 4-level display features
- Switchable power transmission

TBU9000

- Suitable for combination with microphones with 4-pin mini XLR connector
- REMOSET technology for receiver/transmitter synchronisation
- Lock and mute functions
- 6-level display features
- Switchable power transmission

		THU9000	TBU9000
Code		45884	45885
System		Diversity UHF PLL hand-held transmitter	Diversity UHF PLL body-pack transmitter
Frequency Range	MHz	470 - 694	470 - 694
Spurious Emissions	dBc	< - 50	< - 50
Frequency Response	Hz	50 - 18.000	50 - 18.000
Microphone Type		Condenser - cardioid polar pattern	CM501 / CX504 (not included)
Transmitting Power	mW	10 / 50	10 / 50
Operating Time	H	≈ 20	≈ 20
Mic Input Connector		---	4-pin mini XLR
Indicators		LCD + LEDs	LCD + LEDs
Controls		On board	On board
Power Supply	V	UM3. AA x 2	UM3. AA x 2
Power Consumption (@230V)	W	---	---
Weight	Kg	0.255	0.075
	Lb	0.56	0.16

U8000

The U8000 series is comprised of the DRU8002, DRU8001, THU8000 and TBU8000, all of which are designed to cater to specific business needs.

The new U8000 system is available in a **single or dual channel** version, with performance and reliability designed to simplify business life. The **DRU8000** and **DRU8001** receivers feature a compact design and are easy to use with the **hand-held transmitter model THU8000**, offering a perfect mix of convenience and performance. The **TBU8000 body-pack transmitter** completes the range and can be used with the CX-504 and CM-501 headset and lavalier.



THU8000

- Special design to reduce handling noise, structure-borne noise and acoustic feedback
- REMOSET technology for receiver/transmitter synchronisation
- Lock and mute function
- Sensitivity adjustment and power transmission can be configured via receiver
- Low battery alert

Code		45875
System		Diversity UHF PLL hand-held transmitter
Frequency Range	MHz	470 - 694
Spurious Emissions	dBc	< - 50
Frequency Response	Hz	60 - 15.000
Microphone Type		Dynamic - cardioid polar pattern
Transmitting Power	mW	10 / 50
Operating Time	H	≈ 30
Mic Input Connector		---
Indicators		LEDS
Controls		On board
Power Supply	V	UM3. AA x 2
Power Consumption (@230V)		---
Weight	Kg	0.235
	Lb	0.52



TBU8000

- Suitable for combination with microphones with 4-pin mini XLR connector
- REMOSET technology for receiver/transmitter synchronisation
- Lock and mute functions
- Sensitivity adjustment and power transmission can be configured via receiver
- Low battery alert

Code		45876
System		Diversity UHF PLL body-pack transmitter
Frequency Range	MHz	470 - 694
Spurious Emissions	dBc	< - 50
Frequency Response	Hz	60 - 15.000
Microphone Type		CM501 / CX504 (not included)
Transmitting Power	mW	10 / 50
Operating Time	H	≈ 30
Mic Input Connector		4-pin mini XLR
Indicators		LCD + LEDS
Controls		On board
Power Supply	V	UM3. AA x 2
Power Consumption (@230V)		---
Weight	Kg	0.70
	Lb	1.54



DRU8001

- Pilot tone squelch and noise mute
- Fixed antennas
- Auto-scan function
- Backlit display with status indicators

DRU8001 - DRU8002		
Code		45874 - 45877
System		1-channel / 2 channels diversity UHF PLL receiver
Frequency range	MHz	470 - 694
Frequency response	Hz	50 - 16.000
S/N Ratio	dB	> 105dB
THD + N	%	< 0.6 @1KHz
Audio Outputs		DRU8001 : 2 (1 x XLR-M . 1 x 6.3mm Jack) / DRU8002 : 4 (2 x XLR-M . 2 x 6.3mm Jack)
Antenna IN		2 x BNC (+ DC12V / 100mA) only for DRU8002
Indicators		LCD + LEDS
Controls		Front Panels
Mounting		Stand alone
Power Supply	V	12 - 15 (DC)
Power Consumption (@230V)	mA	300 / 500
Dimensions (WxHxD)	mm/ inch	212 x 38 x 144 / 8.35 x 1.5 x 5.66
Weight	Kg / Lb	DRU8001 : 0.470 / 1.03 - DRU8002 : 0.590 / 1.30



DRU8002

- Pilot tone squelch and noise mute
- Removable antennas (BNC connection)
- Power supply for optional antenna booster
- Auto-scan function
- Backlit display with status indications

U8000-U9000 ACCESSORIES



CM-501

- Cardioid polar pattern, suitable for educational and conference applications
- Supplied with clip for easy attachment to a tie, lapel, dress, etc
- Supplied with windshield

Code		27497
System		Lavalier Microphone
Microphone Type		Cardioid - Electret
Frequency Response	Hz	100 - 15,000
Sensitivity	dB	-60dB @ 1KHz
Max SPL	dB	130
Impedance	kΩ	2.2
Connector		4-pin mini XLR
Weight	Kg	0.021
	Lb	0.047



CX-504

- Ergonomic design ensures comfortable wearing
- Cardioid polar pattern
- Supplied with windshield

Code		27498
System		Headset Microphone
Microphone Type		Cardioid - Electret
Frequency Response	Hz	30 - 18,000
Sensitivity	dB	-68dB @ 1KHz
Max SPL	dB	130
Impedance	kΩ	2.2
Connector		4-pin mini XLR
Weight	Kg	0.056
	Lb	0.12



ABU9000

- Power supply via DRU9000/DRU8000 receivers
- DC feed-through output for cascading up to two ABU9000
- Can be wall-mounted or used with microphone stand with 0.62" thread
- Antenna not included

Code		45886
System		Antenna Booster
Frequency Range	MHz	470 - 694
Antenna Gain	dB	10
Coverage	°	360
Indicator		LED
Mounting Type		Wall bracket or 16mm stand (excluded)
Power Supply	V	8 - 12 (DC)
Weight	Kg	0.175
	Lb	0.38

WIRED MICROPHONES

90 HAND-HELD

91 BOUNDARY

92 GOOSENECKS AND BASES

MD-S1000 SERIES

A series of **professional hand-held dynamic microphones** designed for a wide range of applications, from presentations to vocal performances. The series includes two models, the MD-S1100 and MD-S1300, both made to **improve handling noise suppression and feedback reduction**. MD-S1100 features a **dynamic microphone capsule** with **cardioid polar pattern** while the MD-S1300 features a **hyper-cardioid microphone capsule** combined with high quality voice reproduction and low distortion, making it suitable for professional vocal performances.



MD-S 1100

- Durable mechanical construction
- Uniform cardioid directionality
- Frequency response tailored for speech and paging
- Built-in spherical wind and pop filter
- Includes integrated on/off switch

Code		10040
System		Dynamic Hand-held microphone
Directivity		Cardioid
Frequency Response	Hz	80 - 13,000
Sensitivity	dBV/Pa	-75 @ 1KHz
Impedance	Ω	500
Connector		XLR-M
Controls		on/off switch
Material		Diecast zinc body
Mounting		Adapter for stand mounting not provided
Weight	Kg Lb	0.235 0.51



MD-S 1300

- Durable mechanical construction
- Uniform hypercardioid directionality
- Frequency response tailored to vocals
- Built-in spherical wind and pop filter
- Includes integrated on/off switch

Code		10042
System		Dynamic Hand-held microphone
Directivity		Hyper Cardioid
Frequency Response	Hz	50 - 18,000
Sensitivity	dBV/Pa	-72 @ 1KHz
Impedance	Ω	250
Connector		XLR-M
Controls		on/off switch
Material		Diecast zinc body
Mounting		Adapter for stand mounting not provided
Weight	Kg Lb	0.415 0.91

CM-601

The CM-601 boundary microphone is designed for speech applications in meeting, conferencing and house of worship environments. With its **low-profile design** combined with **hemispherical pickup pattern**, it provides consistent, even pickup in front and rejects unwanted sound from the back. CM-601 features **configurable push-button**, standby LED and elastic cartridge suspension for preventing impact and structure-borne noise.



CM 601

- Dual low-cut filter (80 Hz/120 Hz)
- Configurable push-button (PTT, PTM or switching function)
- Robust and shock-absorbing body
- Elastic cartridge suspension for preventing structure-borne noise and impact sound
- Includes 26.2ft cable with mini XLR jack to XLR plug
- Predrilled holes to facilitate wall mounting

Code		27516
System		Electret Condenser boundary microphone
Directivity		Half-Cardioid
Frequency Response	Hz	30 - 12,000
Sensitivity	dBV/Pa	-53 @ 1KHz
Impedance	Ω	100
Max SPL	dB	125
S/N	dB	67
Phantom	VDC	12 - 52
Connector		3P mini XLR-m
Controls		configurable on/off push button
Material		Diecast metal body
Mounting		---
Weight	Kg Lb	0.300 0.66

GM SERIES

The GM series of electret gooseneck microphones is available in **three different lengths**. With a supercardioid polar pattern and **natural sounding frequency response**, it is the ideal choice for meetings, conference rooms and houses of worship. The series provides **low susceptibility to acoustic feedback**, reliability and high-quality construction to ensure **longevity**. Terminating in an integrated 3-pin male XLR for easy connection to the ST 5050 metal gooseneck microphone base or shock-mount connection plate.

KEY FEATURES

- Gooseneck with integrated 3-pin XLR male plug
- Minimum susceptibility to acoustic feedback
- LED for indicating operating status
- Includes foam windscreen



		GM-5206L	GM-5212L	GM-5218L
Code		27515	27514	27513
Characteristics		Electret gooseneck microphone	Electret gooseneck microphone	Electret gooseneck microphone
Directivity		Super Cardioid	Super Cardioid	Super Cardioid
Frequency response	kHz	80 - 18.000	80 - 18.000	80 - 18.000
Sensitivity	dB	-61 @1kHz	-61 @1kHz	-61 @1kHz
Impedance	Ω	220	220	220
Max SPL	dB	125	125	125
Phantom	Vdc	36 - 52	36 - 52	36 - 52
Connector		XLR-M	XLR-M	XLR-M
Indicators		LED	LED	LED
Material		Metal body	Metal body	Metal body
Weight	Kg	0.145	0.165	0.185
	Lb	0.320	0.363	0.407

ST5050

A multipurpose microphone base **suitable for all kinds of condenser and dynamic gooseneck microphones**. It can be quickly mounted via the XLR female socket built into the **robust metal diecast base**.

The ST5050 gooseneck microphone base is the ideal complement to the GM Series.



KEY FEATURES

- Programmable switch can be set to push on/push off, push to talk and push to mute
- Special anti-slip pad ensures stability and reduces bounced reflected noise from desk
- Microphone selecting switch designed for optimum masking effect
- Suitable for all kinds of condenser and dynamic gooseneck microphones

Code		27499
System		Universal Gooseneck Microphone Base
Frequency Response	Hz	20 - 20.000
Mic Connector		XLR-F
OUT Connector		XLR-M
Phantom	VDC	9 - 52 or battery
Battery	VDC	9
Consumption	mA	2.07 mA (BAL), 1.34 mA (UNBAL)
Indicator		LED
Controls		on/off - mic selection - switch mode
Material		Diecast metal body
Weight	Kg	0.82
	Lb	1.8



MBT1101

The MBT1101 preamplified microphone base features an **electret microphone** on a **flexible gooseneck**. Providing **quick setup** and **simple day-to-day** operation when combined with the MPA and MXA compact amplifier series, it is a **cost-effective solution** for paging applications such as in warehouses or retail facilities.

The MBT1101 can be operated in combined or interlocked mode, the latter allowing one station to be activated at a time. Microphone signal levels and chime tones can be adjusted via the rear panel.



KEY FEATURES

- PTT or lock push button with LED status indication
- Adjustable chime and sensitivity levels
- Integrated dynamic limiter
- Configurable mixing and interlocked mode

Code		37739
System		Pre-amplified electret microphone base
Frequency Response	Hz	100 - 15.000
Output Audio Level	V	1.2 (RMS- Balanced)
Connectors		2 x RJ45
Indicators		LED
Controls		PTT-LOCK
Power Supply	VDC	12 - 24 through RJ45
Consumption	mA	45 - 60
Material		Robust ABS body
Weight	Kg	0.600
	Lb	1.32

MB-T6400S

This **compact** and **user-friendly** desktop microphone is ideal for announcements in commercial spaces such as warehouses, factories and retail facilities, its high levels of **sturdiness** and **reliability** making it suitable for industrial environments. It is equipped with a **dynamic cardioid microphone capsule** featuring a **push-to-lock switch**. The MB-T6400S comes with a 16.4ft cable terminating in a professional male XLR connector, plus two conductors for priority activation.



KEY FEATURES

- User-friendly and plug-and-play
- Fully flexible gooseneck shock-mounted to a heavy zinc die cast base
- Low sensitivity to breath and popping sounds
- Includes a 16.4ft cable terminating in XLR-M connector

Code		28840
System		Dynamic desktop microphone
Directivity		Cardioid
Frequency response	Hz	100 - 16.000
Sensitivity	dBV/Pa	-79 @ 1KHz
Impedance	Ω	350
Connector		XLR-M
Controls		on/off push-to-lock button
Material		Diecast zinc body
Weight	Kg	2
	Lb	4.40

BF-T5043L

The BF-T5043L gooseneck condenser microphone with integrated desktop base boasts an elegant design with tailored response for **clear and clean speech reproduction**. It can be used as an **all-in-one solution** for sound reinforcement for small- to mid-sized applications such as AV conferencing, meetings and public speaking. It is equipped with a configurable on/off touch button while a 16.4ft cable terminating in a male XLR connector ensures **quick setup** on podiums or desktops.



KEY FEATURES

- Best-in-class performance, construction and design
- Cardioid polar pattern with tailored response for speech maximises intelligibility
- LED operating status indicator
- Includes a 5m cable terminating in XLR-M connector

Code		18322
System		Electret desktop microphone
Directivity		Cardioid
Frequency response	Hz	70 - 18.000
Sensitivity	dBV/Pa	-59 @ 1KHz
Impedance	Ω	250
Phantom	VDC	12-48
Connector		XLR-M
Controls		on/off touch button
Material		Diecast zinc body
Weight	Kg	0.786
	Lb	1.73

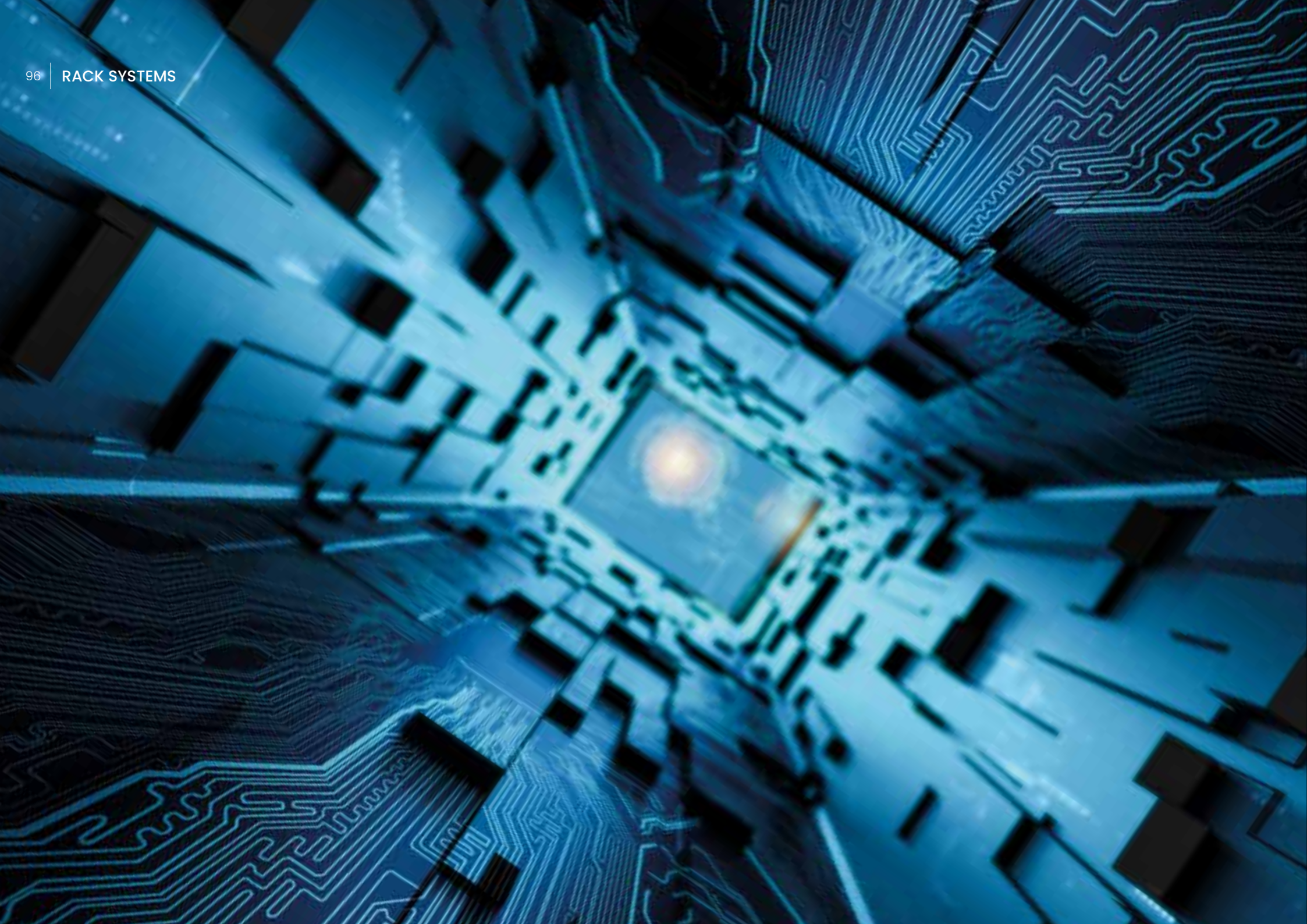

RACK SYSTEMS

98 RACK

100 ACCESSORIES

RACK SYSTEMS

The new floor-standing rack series is specifically designed to house all types of 19" equipment for audio system applications. These racks are engineered to ensure a **sturdiness** that can support the weight of a cabinet fully loaded with professional audio devices.

The series consists of **three models** of rack cabinets for **15, 27** and **42** units, providing options for different storage needs. Additionally, there are **many accessories available** to cater to various applications.

Lockable sides provide convenience for wire management, ensuring that all cables are **organised and protected** within the rack cabinet.

Constructed from a cold rolled steel frame finished in a sleek black powder coating, the rack series is solid, durable and elegant in design. The **tempered glass door** adds a touch of style to the overall appearance of the racks. This series of floor-standing racks offers a reliable, professional solution for housing audio equipment, with a focus on functionality and aesthetics.



RC 4268

Code		45752
Material		Steel
Static Load	Kg / Lb	1000 / 2204.62
Dimensions (WxHxD)	mm	600 x 2055 x 800
	inch	23.62 x 80.90 x 31.49
Net Weight	Kg	105
	Lb	231.48













RC 2768

Code		45751
Material		Steel
Static Load	Kg / Lb	1000 / 2204.62
Dimensions (WxHxD)	mm	600 x 1388 x 800
	inch	23.62 x 54.64 x 31.49
Net Weight	Kg	70
	Lb	154.32



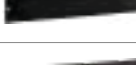
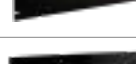

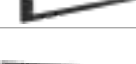







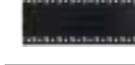

RC 1566

Code		45749
Material		Steel
Static Load	Kg / Lb	1000 / 2204.62
Dimensions (WxHxD)	mm	600 x 855 x 600
	inch	23.62 x 33.66 x 23.62
Net Weight	Kg	44
	Lb	97

	RMD4	45753	4U rack drawer
	RFS600	45754	Fixed 19,09"x13,77" shelf for 23,62"x31,49" rack cabinet
	RFS800	45755	Fixed shelf 19,09"x13,77" for rack cabinet 23,62"x31,49"
	RSS800	45756	Sliding 16,53"x21,65" shelf for 19" rack cabinets
	RMR600	45757	Set of two dedicated 13,77" mounting rails for 23,62"x23,62" rack cabinets
	RMR800	45758	Set of two dedicated 350mm mounting rails for 23,62"x31,49" rack cabinets
	RBP1	45759	Blank 1U
	RBP2	45760	Blank 2U
	RBP3	45761	Blank 3U
	RBP4	45762	Blank 4U
	RBPIT	45763	Brush grommet for rack cabinets
	RBP1F	45764	Brush strip panel with 1U rack
	RCMIH	45765	Horizontal metal cable management panel for 1U rack



	RCMIHP	45766	Horizontal plastic cable management panel for 1U rack
	RCMIV	45767	Cable management panel for vertical rack cabinets
	RMP4	45777	4U mounting plate with DIN-TH35-24xS rail for 19" rack
	RCUI	45768	Four-fan unit with thermostat for 1U rack cabinets
	RPDI	45769	230VAC 8-socket/type F power distribution unit
	RBK800	45770	39,37" plinth for 23,62"x31,49" floor-standing cabinets
	RWK1	45771	2" Rack wheel kit without brake for floor-standing cabinets
	RWK1B	45772	2" Rack wheel kit with brake for floor-standing cabinets
	RLF1	45773	Levelling foot for floor-standing cabinets
	RRL1	45774	Rack round lock kit for front and rear door with two keys
	RRL1S	45775	Rack round lock kit for side panels with two keys
	RLK1	45776	Universal front door lock for rack cabinets

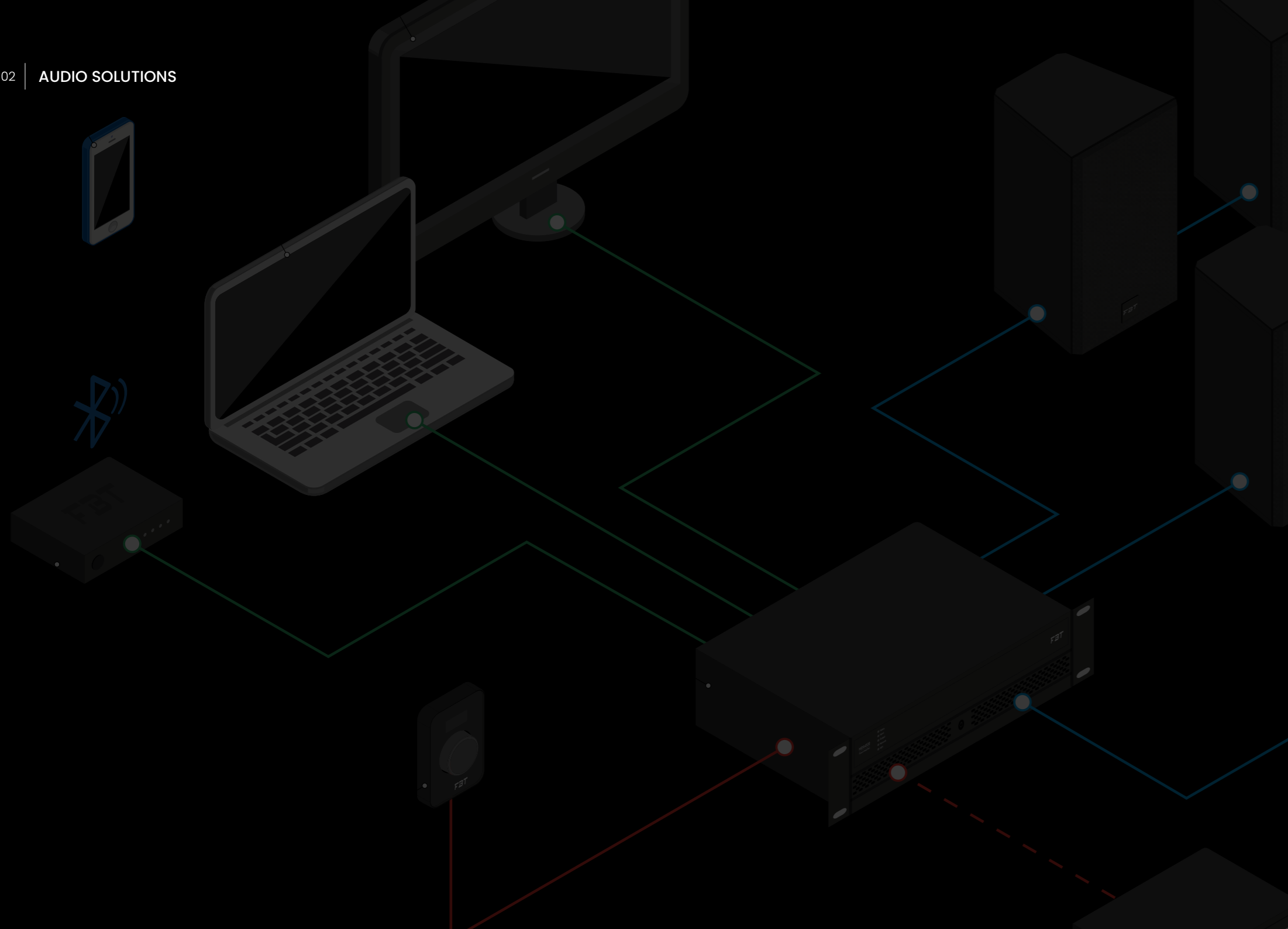

AUDIO SOLUTIONS

The following audio solutions guide is designed as a comprehensive resource for professionals across various sectors who are seeking to enhance their auditory communication systems.

- 104** BACKGROUND MUSIC
- 108** FOREGROUND MUSIC
- 110** MEETINGS & CONFERENCE
- 112** PAGING & BGM
- 114** SPEECH
- 116** SPORT FACILITY

BACKGROUND MUSIC

These audio solutions are suitable for applications where the reproduction of musical content at low-to-medium levels is required, with good spatial distribution and adequate tonal balance. The loudspeakers used in these applications are discreet and compact, offering customisable aesthetics in some cases, with an adequate frequency response to provide a comfortable and relaxing listening experience.

The management and amplification system can be either integrated or scalable, both featuring an intuitive user interface with analogue controls or via an app.

These audio solutions for background music are optimised by simple installation and competitive performance.

CAFÈ

ZONES:
SINGLE

SPEAKER WIRING:
HIGH IMPEDANCE

EQUIPMENT RANGE:
PROJECT SERIES, 4WAVE, MDS SERIES



RESTAURANT

ZONES:
SINGLE

SPEAKER WIRING:
HIGH IMPEDANCE

EQUIPMENT RANGE:
KEIRON 4C, 4WAVE, MDA SERIES

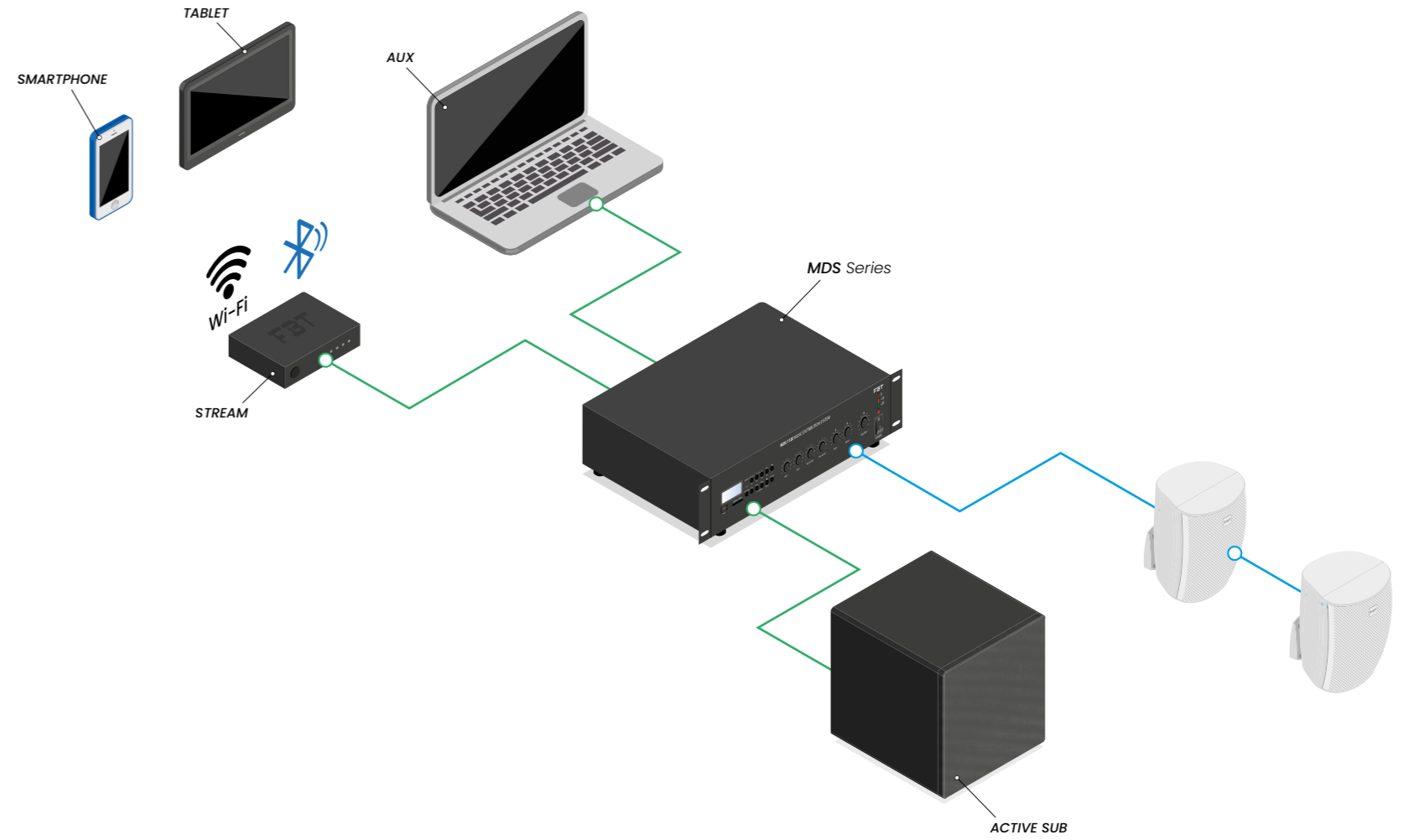

— 2C Speaker Cable
 — 2C + Shield Signal Cable

BACKGROUND MUSIC

These audio solutions are suitable for applications where the reproduction of musical content at low-to-medium levels is required, with good spatial distribution and adequate tonal balance. The loudspeakers used in these applications are discreet and compact, offering customisable aesthetics in some cases, with an adequate frequency response to provide a comfortable and relaxing listening experience.

The management and amplification system can be either integrated or scalable, both featuring an intuitive user interface with analogue controls or via an app.

These audio solutions for background music are optimised by simple installation and competitive performance.

STORE & SHOP

ZONES:
SINGLE

SPEAKER WIRING:
LOW IMPEDANCE

EQUIPMENT RANGE:
KEIRON 5C, KEIRON 8S, 4WAVE, MDA SERIES



SHOWROOM & DEALER

ZONES:
SINGLE

SPEAKER WIRING:
LOW IMPEDANCE

EQUIPMENT RANGE:
LIBRA SERIES, ELYSION, STREAMER, MDA SERIES

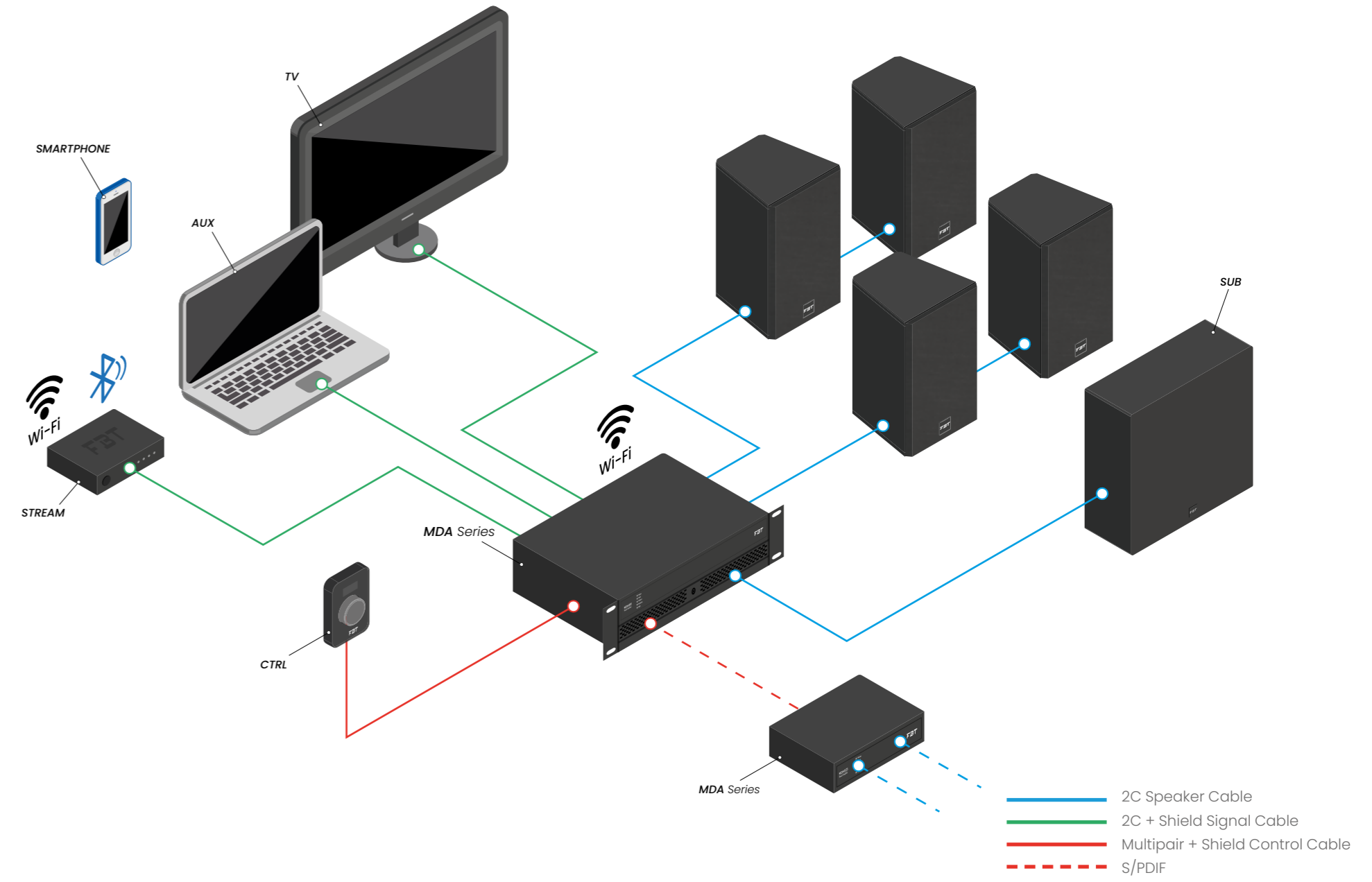

FOREGROUND MUSIC

Custom-designed sound reinforcement systems that extend across multiple audio zones with varying acoustics and user requirements, necessitating a medium-to-high level of reproduction, extensive frequency response and adaptable tonal balance to suit the context of use, whether background music, live music or DJ sets.

The compact loudspeakers offer uncompromising performance while maintaining elegant lines with customisable finishes to seamlessly integrate into interior designs.

Management system can be either centralised or scalable. Sophisticated audio signal processing is simplified by an effective user interface for managing sources, scenes settings and audio zones.

LUXURY HOME

ZONES:
4 (1 STEREO)

SPEAKER WIRING:
LOW IMPEDANCE

EQUIPMENT RANGE:
KEIRON 5C, CLA 204T, CLA 803T, CLA 112S, KEIRON 8S, DM-8208, MDA SERIES



LOUNGE / BAR / RESTAURANT

ZONES:
5 (2 STEREO)

SPEAKER WIRING:
LOW IMPEDANCE

EQUIPMENT RANGE:
KEIRON 8C, KEIRON 5C, CLA204T, KEIRON 8S, DM-8208, MDA4 SERIES

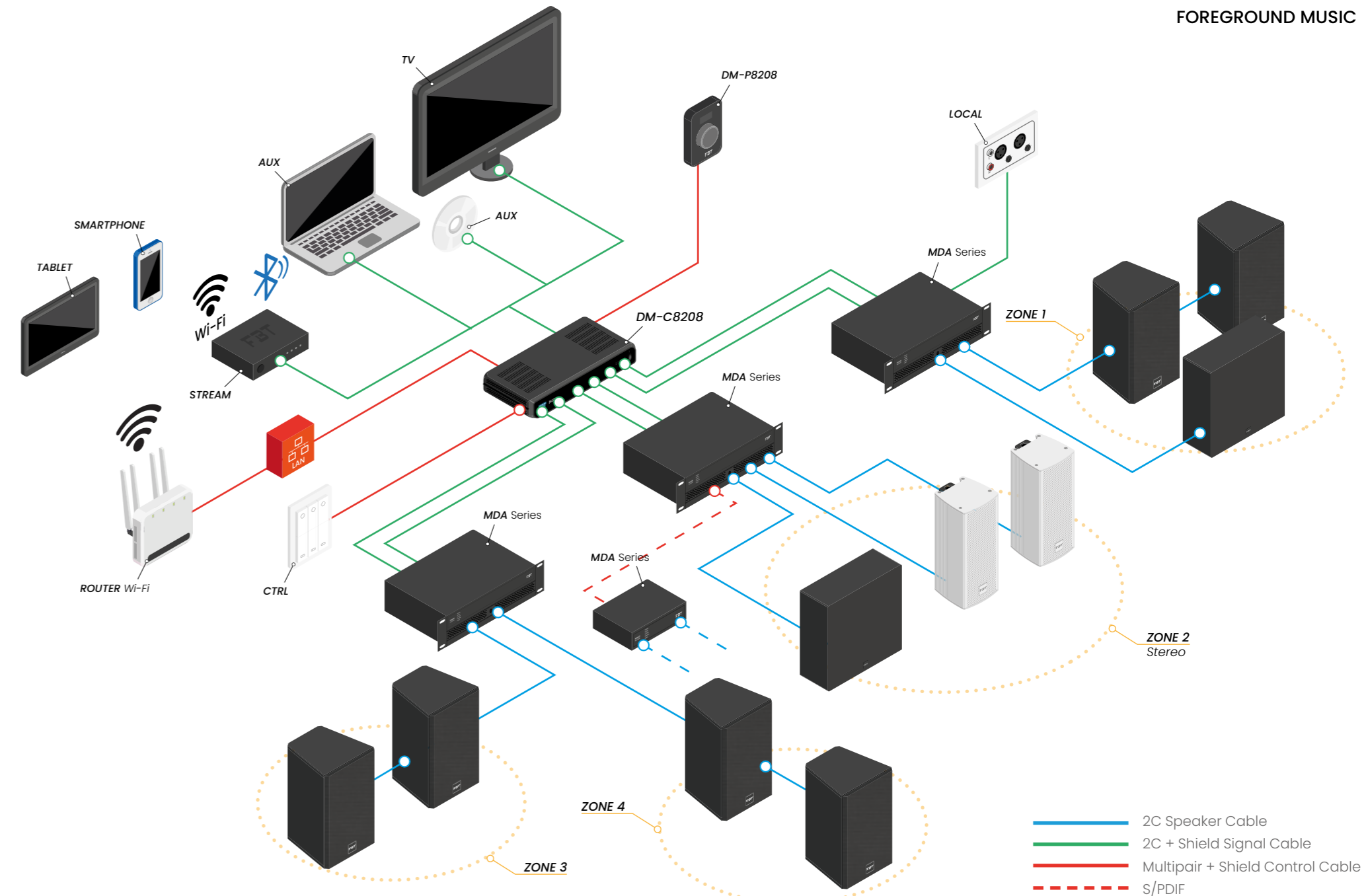
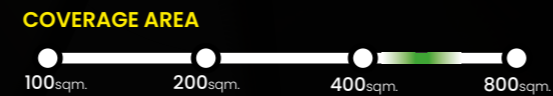

MEETINGS & CONFERENCE

Solutions built for all applications that require dynamic and effective management of multiple and varied audio sources: microphones, wireless microphones, conference systems and AV recording/playback devices with wide-range reproduction suitable for both voice and multimedia content.

Line array loudspeakers boast a directivity that maximises the direct field/reverberated field ratio in the listening area to achieve optimal speech intelligibility for understanding semantically complex content.

Audio solutions of this type usually require an open user interface, which can be designed upon request.

CONVENTION CENTER

ZONES:
1

SPEAKER WIRING:
LOW IMPEDANCE / POWERED SPEAKERS

EQUIPMENT RANGE:
DLA SERIES, CLA SERIES, CSU SERIES, MDA SERIES

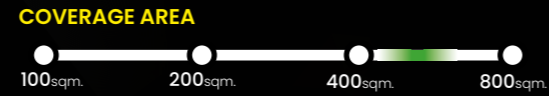

LARGE & MODULAR CONFERENCE ROOMS

ZONES:
3

SPEAKER WIRING:
LOW IMPEDANCE / POWERED SPEAKERS

EQUIPMENT RANGE:
DLA SERIES, CLA SERIES, CSU SERIES, DMM8008, MDA SERIES

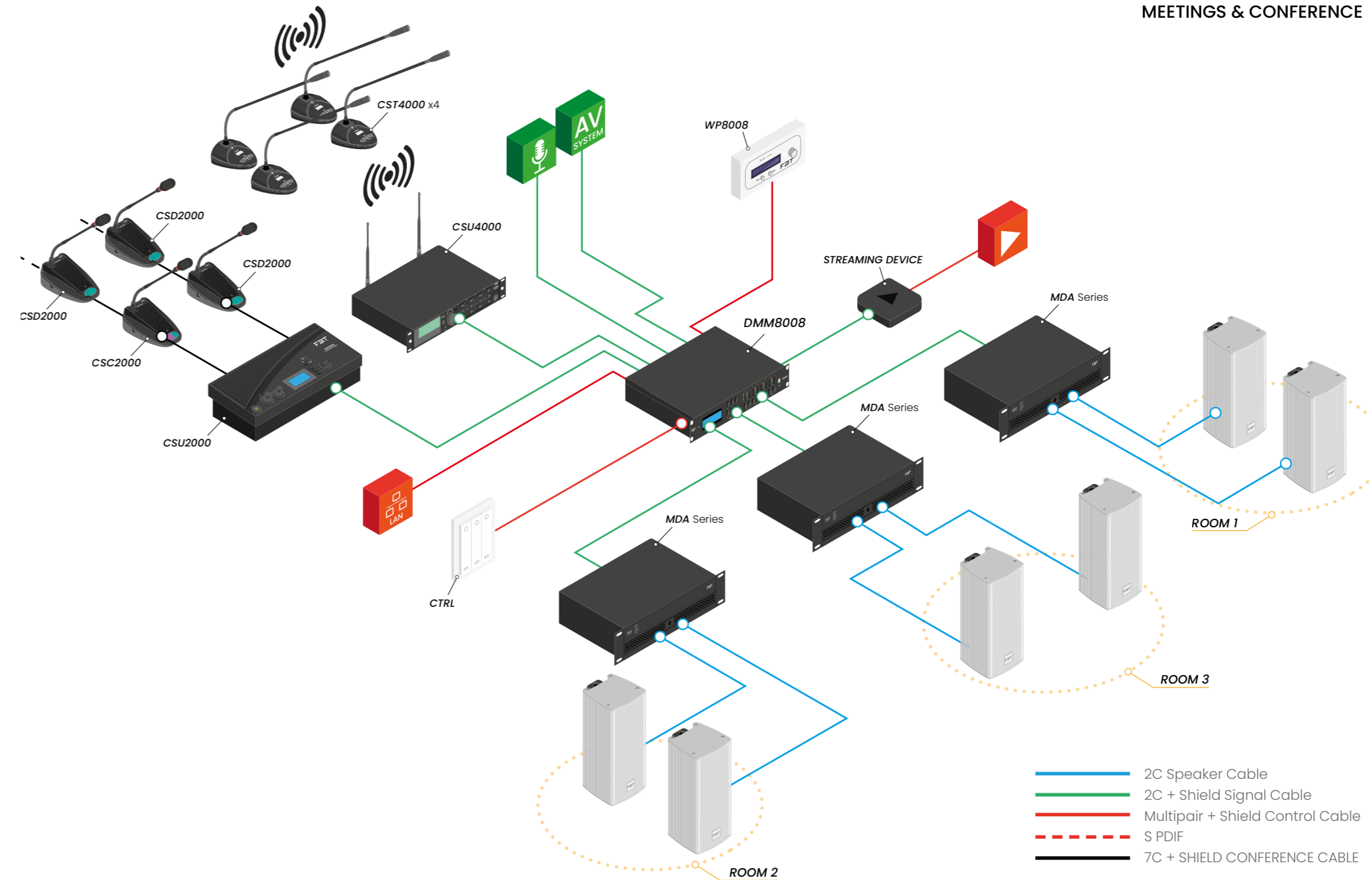
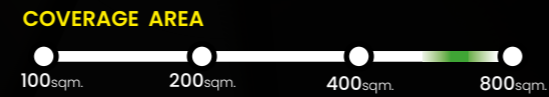

PAGING & BGM

The audio systems in this category meet the fundamental requirement of being centrally managed.

One or more operators can direct voice messages and/or background music to individual zones or groups of zones which can be managed remotely, so that the music source can be selected and the volume set in each individual zone.

Typical applications include hotels, commercial parks and any multifunctional facility that hosts various activities interconnected by common areas.

These speakers offer versatility by providing numerous installation methods, with in-ceiling, suspended and wall-mounted solutions, as well as a choice of customisable colours, all without sacrificing reproduction quality.

HOTEL & RESORT

ZONES:
6

SPEAKER WIRING:
HIGH IMPEDANCE

EQUIPMENT RANGE:
CSL SERIES, CLA 204, ELYSION, LIBRA, DM-8208,
MDA SERIES, KEIRON 4C



SHOPPING MALL

ZONES:
8

SPEAKER WIRING:
HIGH IMPEDANCE

EQUIPMENT RANGE:
CSL SERIES, CLA 204, KEIRON 4C, ELYSION, LIBRA,
DM-8208, MDA SERIES

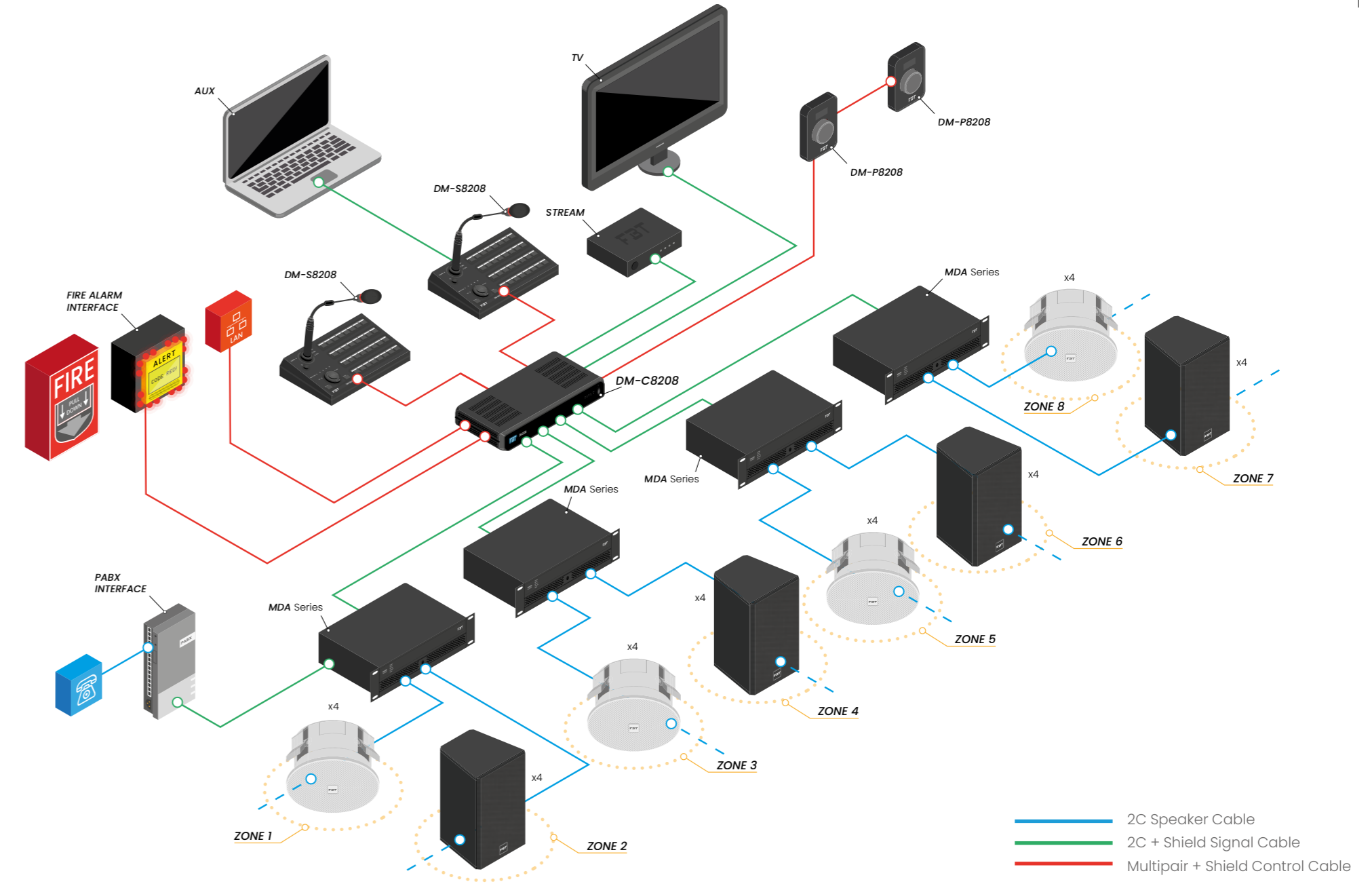

SPEECH

The goal of speech solutions is to achieve an acceptable intelligibility index in acoustically critical situations where there might be restrictions on where speakers can be installed.

The design of these solutions assesses all critical factors through 3D modelling to achieve the desired performance.

Whether in simpler applications such as university classrooms or more complex ones like cathedrals, these active or passive line array loudspeakers feature digital beam steering control to minimise the reverberant field in the listening area.

Using sophisticated digital automixing algorithms, the management and amplification system can effectively handle multiple types of microphones and audio sources.

CLASSROOM & LECTURE HALL

ZONES:
1

SPEAKER WIRING:
LOW IMPEDANCE

EQUIPMENT RANGE:
CLA SERIES, CSU SERIES, DMM8008, MDA SERIES

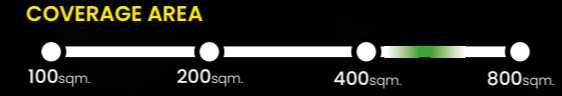

CHURCH & CATHEDRAL

ZONES:
2

SPEAKER WIRING:
LOW IMPEDANCE / POWERED SPEAKERS

EQUIPMENT RANGE:
DLA SERIES, CLA SERIES, GM SERIES, DRU SERIES, DMM 8008, MDA SERIES

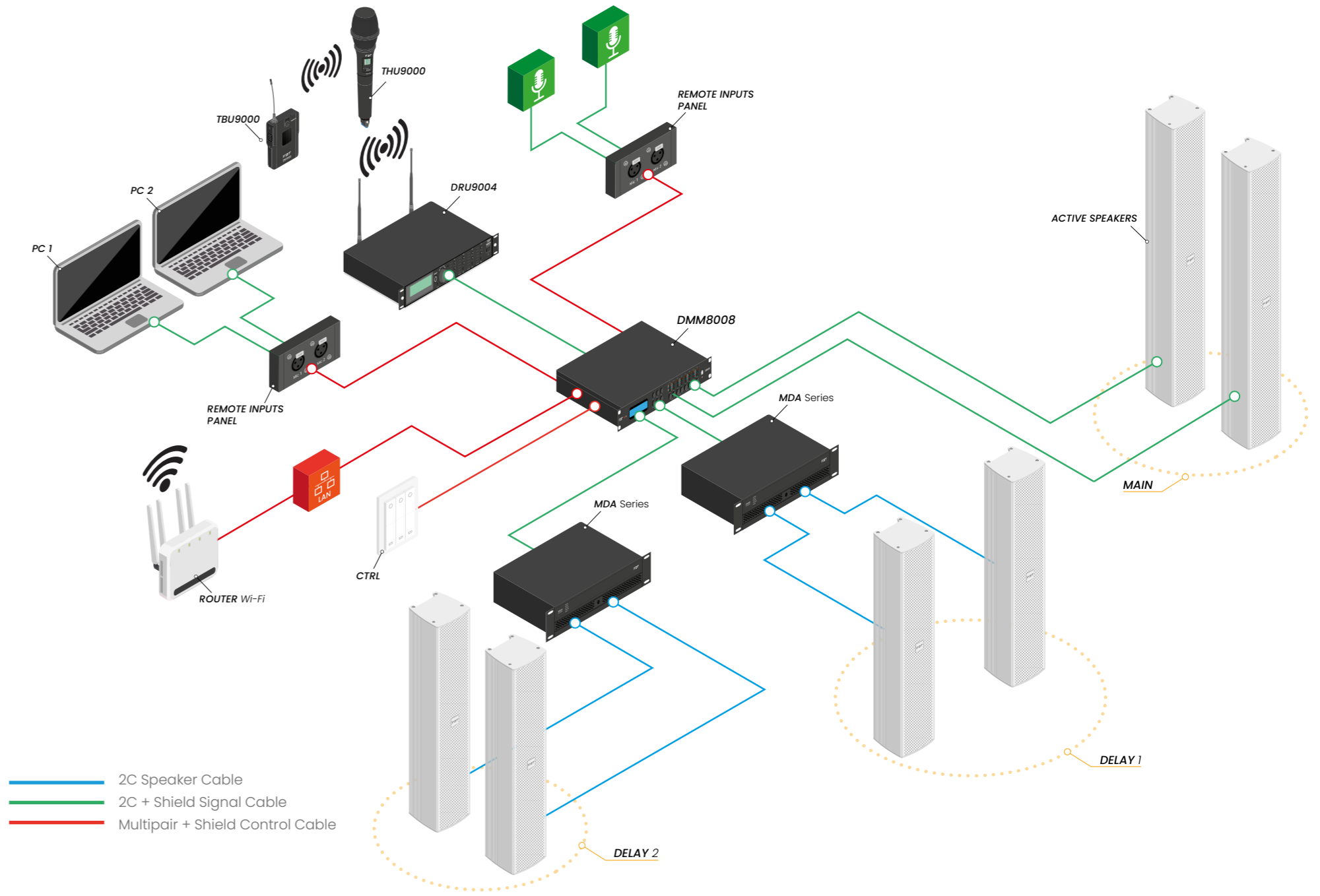
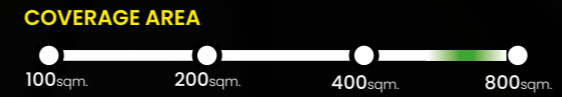

SPORT FACILITY

The focus of modern sports arenas is to create an immersive experience for the audience, increasing physical and emotional engagement.

Central to this goal is a meticulous audio system design, delivering a consistent frequency response across the entire listening area and reproducing a deep, intense bass and well-defined mid-highs.

The listening level must ensure an adequate signal-to-noise ratio for accurate comprehension of audience announcements.

The speakers designed for these applications are built with technical/mechanical measurements and electro-acoustic components that enhance reliability and performance while offering IP protection rating.

The management and amplification system must be capable of supporting networking for both audio transport and control, which should be flexible and capable of interfacing with third-party systems.

MULTIPURPOSE INDOOR ARENA

ZONES:

4

SPEAKER WIRING:

LOW / HIGH IMPEDANCE

EQUIPMENT RANGE:

SHADOW 112CT, SHADOW 108CT, DM-8208, MDA SERIES

COVERAGE AREA



SOUND LVL



OUTDOOR STADIUM

ZONES:

6

SPEAKER WIRING:

LOW / HIGH IMPEDANCE

EQUIPMENT RANGE:

SHADOW 142L, SHADOW 112CT, DM-8208, DMM 8008, MDA SERIES

COVERAGE AREA



SOUND LVL

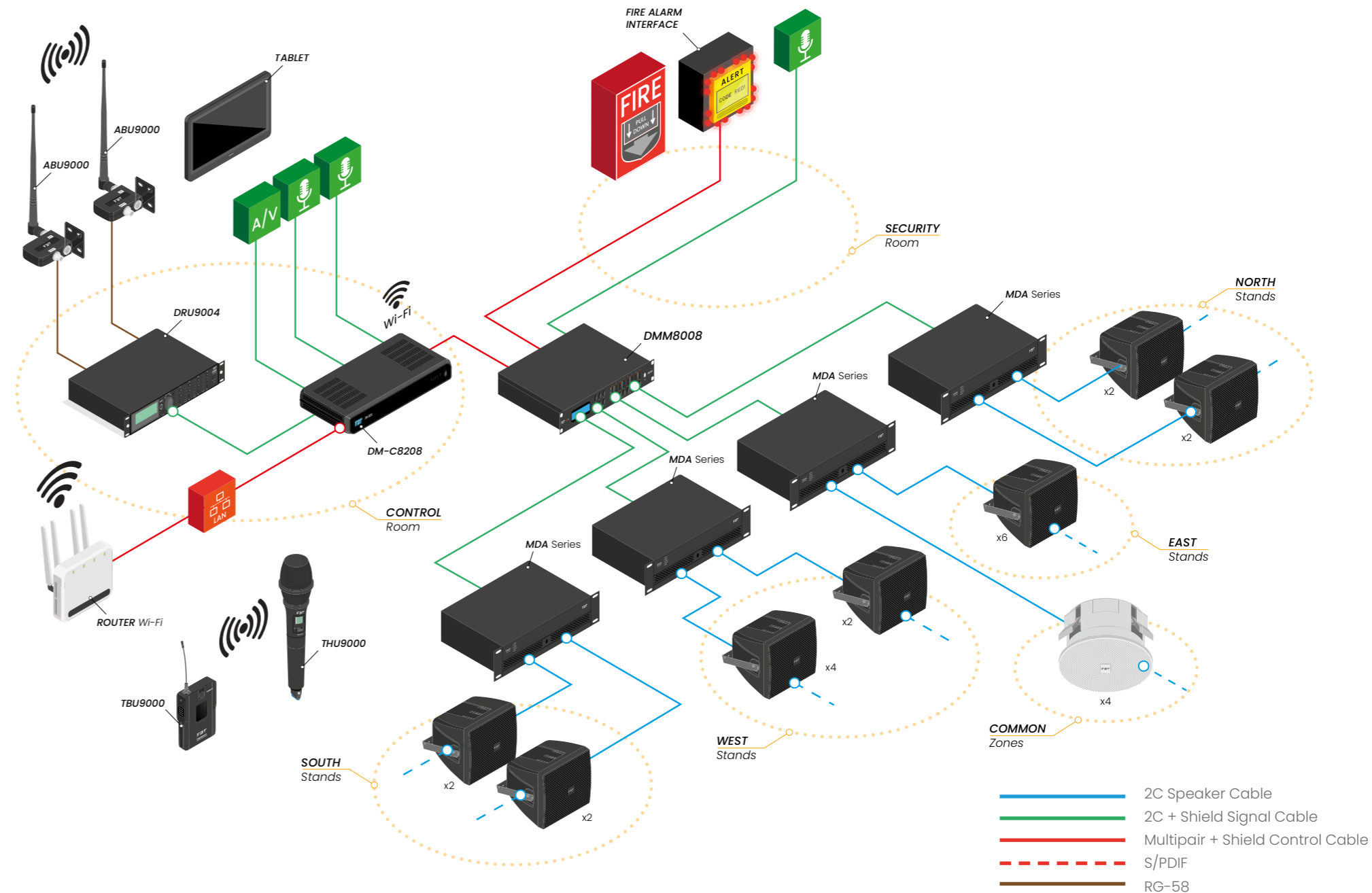



FBT.IT



FBT ELETTRONICA SPA

Via Paolo Soprani, 1 - 62019, Recanati (MC), Italy

Tel. +39 071 750591

info@fbt.it - www.fbt.it

FBT strives to improve its products on a continual basis. Specifications are therefore subject to change without notice.

All data presented in this catalogue represents the basic performance specifications for each model. For a detailed analysis of specifications please check the technical documentation of the products available at www.fbt.it.

The "Audio Solutions" section gives examples of how FBT products can be combined to offer complete systems for a wide range of applications and should be considered as a general guide for reaching the standard performance required in each scenario. Each venue design must be approached individually to address the performance requirements. Please contact the FBT design department for support.

CONTRACTOR CATALOGUE
Ver. 1.1 (09/2024)



CONTRACTOR
CATALOGUE 2024/2025